

# Product data sheet

Specifications



## Variable speed drive, Altivar Process ATV900, ATV930, 30 kW, 400/480 V, with braking unit, IP21

ATV930D30N4

### Main

<b>Range of product</b>	Altivar Process ATV900
<b>Device application</b>	Industrial application
<b>Product or component type</b>	Variable speed drive
<b>Product destination</b>	Asynchronous motors Synchronous motors
<b>Product specific application</b>	Process for industrial
<b>Variant</b>	With braking chopper Standard version
<b>Network number of phases</b>	3 phases
<b>Mounting mode</b>	Wall mount
<b>Communication port protocol</b>	Modbus serial EtherNet/IP Modbus TCP
<b>[Us] rated supply voltage</b>	380...480 V - 15...10 %
<b>Nominal output current</b>	61.5 A
<b>Motor power kW</b>	30.0 kW for normal duty 22.0 kW for heavy duty
<b>Motor power hp</b>	40.0 hp for normal duty 30.0 hp for heavy duty
<b>Continuous output current</b>	61.5 A at 4 kHz for normal duty 46.3 A at 4 kHz for heavy duty
<b>EMC filter</b>	Integrated With EMC plate option
<b>IP degree of protection</b>	IP21
<b>Degree of protection</b>	UL type 1
<b>Option module</b>	Slot A: communication module for Profibus DP V1 Slot A: communication module for Profinet Slot A: communication module for DeviceNet Slot A: communication module for EtherCAT Slot A: communication module for CANopen daisy chain RJ45 Slot A: communication module for CANopen SUB-D 9 Slot A: communication module for CANopen screw terminals Slot A/slot B/slot C: digital and analog I/O extension module Slot A/slot B/slot C: output relay extension module Slot B: 5/12 V digital encoder interface module Slot B: analog encoder interface module Slot B: resolver encoder interface module communication module for Ethernet Powerlink

## Complementary

<b>Discrete input number</b>	10
<b>Discrete input type</b>	DI1...DI8 programmable, 24 V DC ( $\leq 30$ V), impedance: 3.5 kOhm DI7, DI8 programmable as pulse input: 0...30 kHz, 24 V DC ( $\leq 30$ V) STOA, STOB safe torque off, 24 V DC ( $\leq 30$ V), impedance: $> 2.2$ kOhm
<b>Discrete input logic</b>	16 preset speeds
<b>Discrete output number</b>	2
<b>Discrete output type</b>	Logic output DQ+ 0...1 kHz $\leq 30$ V DC 100 mA Programmable as pulse output DQ+ 0...30 kHz $\leq 30$ V DC 20 mA Logic output DQ- 0...1 kHz $\leq 30$ V DC 100 mA
<b>Analogue input number</b>	3
<b>Analogue input type</b>	AI1, AI2, AI3 software-configurable voltage: 0...10 V DC, impedance: 30 kOhm, resolution 12 bits AI1, AI2, AI3 software-configurable current: 0...20 mA/4...20 mA, impedance: 250 Ohm, resolution 12 bits
<b>Analogue output number</b>	2
<b>Analogue output type</b>	Software-configurable voltage AQ1, AQ2: 0...10 V DC impedance 470 Ohm, resolution 10 bits Software-configurable current AQ1, AQ2: 0...20 mA impedance 500 Ohm, resolution 10 bits
<b>Relay output number</b>	3
<b>Relay output type</b>	Configurable relay logic R1: fault relay NO/NC electrical durability 100000 cycles Configurable relay logic R2: sequence relay NO electrical durability 1000000 cycles Configurable relay logic R3: sequence relay NO electrical durability 1000000 cycles
<b>Maximum switching current</b>	Relay output R1 on resistive load, $\cos \phi = 1$ : 3 A at 250 V AC Relay output R1 on resistive load, $\cos \phi = 1$ : 3 A at 30 V DC Relay output R1 on inductive load, $\cos \phi = 0.4$ and $L/R = 7$ ms: 2 A at 250 V AC Relay output R1 on inductive load, $\cos \phi = 0.4$ and $L/R = 7$ ms: 2 A at 30 V DC Relay output R2, R3 on resistive load, $\cos \phi = 1$ : 5 A at 250 V AC Relay output R2, R3 on resistive load, $\cos \phi = 1$ : 5 A at 30 V DC Relay output R2, R3 on inductive load, $\cos \phi = 0.4$ and $L/R = 7$ ms: 2 A at 250 V AC Relay output R2, R3 on inductive load, $\cos \phi = 0.4$ and $L/R = 7$ ms: 2 A at 30 V DC
<b>Minimum switching current</b>	Relay output R1, R2, R3: 5 mA at 24 V DC
<b>Physical interface</b>	Ethernet 2-wire RS 485
<b>Connector type</b>	2 RJ45 1 RJ45
<b>Method of access</b>	Slave Modbus TCP
<b>Transmission rate</b>	10, 100 Mbits 4.8 kbps 9600 bit/s 19200 bit/s
<b>Transmission frame</b>	RTU
<b>Number of addresses</b>	1...247
<b>Data format</b>	8 bits, configurable odd, even or no parity
<b>Type of polarization</b>	No impedance
<b>4 quadrant operation possible</b>	True
<b>Asynchronous motor control profile</b>	Constant torque standard Variable torque standard Optimized torque mode
<b>Synchronous motor control profile</b>	Permanent magnet motor Synchronous reluctance motor
<b>Maximum output frequency</b>	599 Hz
<b>Acceleration and deceleration ramps</b>	Linear adjustable separately from 0.01...9999 s
<b>Motor slip compensation</b>	Can be suppressed Automatic whatever the load Adjustable Not available in permanent magnet motor law
<b>Switching frequency</b>	2...16 kHz adjustable 4...16 kHz with derating factor

<b>Nominal switching frequency</b>	4 kHz
<b>Braking to standstill</b>	By DC injection
<b>Brake chopper integrated</b>	True
<b>Line current</b>	53.3 A at 380 V (normal duty) 40.5 A at 380 V (heavy duty) 45.9 A at 480 V (normal duty) 35.8 A at 480 V (heavy duty)
<b>Maximum input current</b>	53.3 A
<b>Maximum output voltage</b>	480.0 V
<b>Apparent power</b>	38.1 kVA at 480 V (normal duty) 29.8 kVA at 480 V (heavy duty)
<b>Maximum transient current</b>	73.8 A during 60 s (normal duty) 69.5 A during 60 s (heavy duty)
<b>Network frequency</b>	50...60 Hz
<b>Relative symmetric network frequency tolerance</b>	5 %
<b>Prospective line I<sub>sc</sub></b>	50 kA
<b>Base load current at high overload</b>	46.3 A
<b>Base load current at low overload</b>	61.5 A
<b>Power dissipation in W</b>	Natural convection: 93 W at 380 V, switching frequency 4 kHz Forced convection: 640 W at 380 V, switching frequency 4 kHz
<b>With safety function Safely Limited Speed (SLS)</b>	True
<b>With safety function Safe brake management (SBC/SBT)</b>	True
<b>With safety function Safe Operating Stop (SOS)</b>	False
<b>With safety function Safe Position (SP)</b>	False
<b>With safety function Safe programmable logic</b>	False
<b>With safety function Safe Speed Monitor (SSM)</b>	False
<b>With safety function Safe Stop 1 (SS1)</b>	True
<b>With sft fct Safe Stop 2 (SS2)</b>	False
<b>With safety function Safe torque off (STO)</b>	True
<b>With safety function Safely Limited Position (SLP)</b>	False
<b>With safety function Safe Direction (SDI)</b>	False
<b>Protection type</b>	Thermal protection: motor Safe torque off: motor Motor phase break: motor Thermal protection: drive Safe torque off: drive Overheating: drive Overcurrent between output phases and earth: drive Overload of output voltage: drive Short-circuit protection: drive Motor phase break: drive Overvoltages on the DC bus: drive Line supply overvoltage: drive Line supply undervoltage: drive Line supply phase loss: drive Overspeed: drive Break on the control circuit: drive

<b>Quantity per set</b>	1
<b>Width</b>	226 mm
<b>Height</b>	673 mm
<b>Depth</b>	274 mm
<b>Net weight</b>	28 kg
<b>Electrical connection</b>	Control: screw terminal 0.5...1.5 mm <sup>2</sup> /AWG 20...AWG 16 Line side: screw terminal 25...50 mm <sup>2</sup> /AWG 4...AWG 1 Motor: screw terminal 25...50 mm <sup>2</sup> /AWG 4...AWG 1 DC bus: screw terminal 25...50 mm <sup>2</sup> /AWG 4...AWG 1
<b>Transmission rate</b>	10/100 Mbit/s for Ethernet IP/Modbus TCP 4.8, 9.6, 19.2, 38.4 kbit/s for Modbus serial
<b>Exchange mode</b>	Half duplex, full duplex, autonegotiation Ethernet IP/Modbus TCP
<b>Data format</b>	8 bits, configurable odd, even or no parity for Modbus serial
<b>Type of polarization</b>	No impedance for Modbus serial
<b>Number of addresses</b>	1...247 for Modbus serial
<b>Supply</b>	External supply for digital inputs: 24 V DC (19...30 V), <1.25 mA, protection type: overload and short-circuit protection Internal supply for reference potentiometer (1 to 10 kOhm): 10.5 V DC +/- 5 %, <10 mA, protection type: overload and short-circuit protection Internal supply for digital inputs and STO: 24 V DC (21...27 V), <200 mA, protection type: overload and short-circuit protection
<b>Local signalling</b>	Local diagnostic: 3 LED (mono/dual colour) Embedded communication status: 5 LED (dual colour) Communication module status: 2 LED (dual colour) Presence of voltage: 1 LED (red)
<b>Input compatibility</b>	DI1...DI8: discrete input level 1 PLC conforming to EN/IEC 61131-2 DI7, DI8: pulse input level 1 PLC conforming to IEC 65A-68 STOA, STOB: discrete input level 1 PLC conforming to EN/IEC 61131-2
<b>Discrete input logic</b>	Positive logic (source) (DI1...DI8), < 5 V (state 0), > 11 V (state 1) Negative logic (sink) (DI1...DI8), > 16 V (state 0), < 10 V (state 1) Positive logic (source) (DI7, DI8), < 0.6 V (state 0), > 2.5 V (state 1) Positive logic (source) (STOA, STOB), < 5 V (state 0), > 11 V (state 1)
<b>Sampling duration</b>	2 ms +/- 0.5 ms (DI1...DI8) - discrete input 5 ms +/- 1 ms (DI7, DI8) - pulse input 1 ms +/- 1 ms (AI1, AI2, AI3) - analog input 5 ms +/- 1 ms (AQ1, AQ2) - analog output
<b>Accuracy</b>	+/- 0.6 % AI1, AI2, AI3 for a temperature variation 60 °C analog input +/- 1 % AQ1, AQ2 for a temperature variation 60 °C analog output
<b>Linearity error</b>	AI1, AI2, AI3: +/- 0.15 % of maximum value for analog input AQ1, AQ2: +/- 0.2 % for analog output
<b>Refresh time</b>	Relay output (R1, R2, R3): 5 ms (+/- 0.5 ms)
<b>Isolation</b>	Between power and control terminals
<b>Environment</b>	
<b>Operating altitude</b>	<= 1000 m without derating 1000...4800 m with current derating 1 % per 100 m
<b>Operating position</b>	Vertical +/- 10 degree
<b>Product certifications</b>	TÜV CSA UL
<b>Marking</b>	CE
<b>Standards</b>	UL 508C EN/IEC 61800-3 EN/IEC 61800-5-1 IEC 61000-3-12 IEC 60721-3 IEC 61508 IEC 13849-1
<b>Maximum THDI</b>	<48 % from 80...100 % of load conforming to IEC 61000-3-12
<b>Assembly style</b>	Enclosed

<b>Electromagnetic compatibility</b>	Electrostatic discharge immunity test level 3 conforming to IEC 61000-4-2 Radiated radio-frequency electromagnetic field immunity test level 3 conforming to IEC 61000-4-3 Electrical fast transient/burst immunity test level 4 conforming to IEC 61000-4-4 1.2/50 $\mu$ s - 8/20 $\mu$ s surge immunity test level 3 conforming to IEC 61000-4-5 Conducted radio-frequency immunity test level 3 conforming to IEC 61000-4-6
<b>Environmental class (during operation)</b>	Class 3C3 according to IEC 60721-3-3 Class 3S3 according to IEC 60721-3-3
<b>Maximum acceleration under shock impact (during operation)</b>	150 m/s <sup>2</sup> at 11 ms
<b>Maximum acceleration under vibrational stress (during operation)</b>	10 m/s <sup>2</sup> at 13...200 Hz
<b>Maximum deflection under vibratory load (during operation)</b>	1.5 mm at 2...13 Hz
<b>Permitted relative humidity (during operation)</b>	Class 3K5 according to EN 60721-3
<b>Volume of cooling air</b>	240 m <sup>3</sup> /h
<b>Overvoltage category</b>	III
<b>Regulation loop</b>	Adjustable PID regulator
<b>Insulation resistance</b>	> 1 MOhm 500 V DC for 1 minute to earth
<b>Noise level</b>	71.5 dB conforming to 86/188/EEC
<b>Vibration resistance</b>	1.5 mm peak to peak (f= 2...13 Hz) conforming to IEC 60068-2-6 1 gn (f= 13...200 Hz) conforming to IEC 60068-2-6
<b>Shock resistance</b>	15 gn for 11 ms conforming to IEC 60068-2-27
<b>Environmental characteristic</b>	Chemical pollution resistance class 3C3 conforming to EN/IEC 60721-3-3 Dust pollution resistance class 3S3 conforming to EN/IEC 60721-3-3
<b>Relative humidity</b>	5...95 % without condensation conforming to IEC 60068-2-3
<b>Ambient air temperature for operation</b>	-15...50 °C (without derating) 50...60 °C (with derating factor)
<b>Noise level</b>	71.5 dB
<b>Pollution degree</b>	2
<b>Ambient air transport temperature</b>	-40...70 °C
<b>Ambient air temperature for storage</b>	-40...70 °C

## Packing Units

<b>Unit Type of Package 1</b>	PCE
<b>Number of Units in Package 1</b>	1
<b>Package 1 Weight</b>	28.7 kg
<b>Package 1 Height</b>	50 cm
<b>Package 1 width</b>	34.5 cm
<b>Package 1 Length</b>	84.5 cm
<b>Unit Type of Package 2</b>	P06
<b>Number of Units in Package 2</b>	1
<b>Package 2 Weight</b>	37.2 kg
<b>Package 2 Height</b>	77 cm
<b>Package 2 width</b>	80 cm
<b>Package 2 Length</b>	60 cm

## Offer Sustainability

<b>Sustainable offer status</b>	Green Premium product
<b>REACH Regulation</b>	<a href="#">REACH Declaration</a>
<b>EU RoHS Directive</b>	Pro-active compliance (Product out of EU RoHS legal scope) <a href="#">EU RoHS Declaration</a>
<b>Mercury free</b>	Yes
<b>RoHS exemption information</b>	Yes
<b>China RoHS Regulation</b>	<a href="#">China RoHS declaration</a>
<b>Environmental Disclosure</b>	<a href="#">Product Environmental Profile</a>
<b>Circularity Profile</b>	<a href="#">End of Life Information</a>
<b>WEEE</b>	The product must be disposed on European Union markets following specific waste collection and never end up in rubbish bins
<b>California proposition 65</b>	WARNING: This product can expose you to chemicals including: Lead and lead compounds, which is known to the State of California to cause cancer and birth defects or other reproductive harm. For more information go to <a href="http://www.P65Warnings.ca.gov">www.P65Warnings.ca.gov</a>
<b>Upgradeability</b>	<a href="#">Upgraded components available</a> 

Dimensions

Front, Left and Rear View

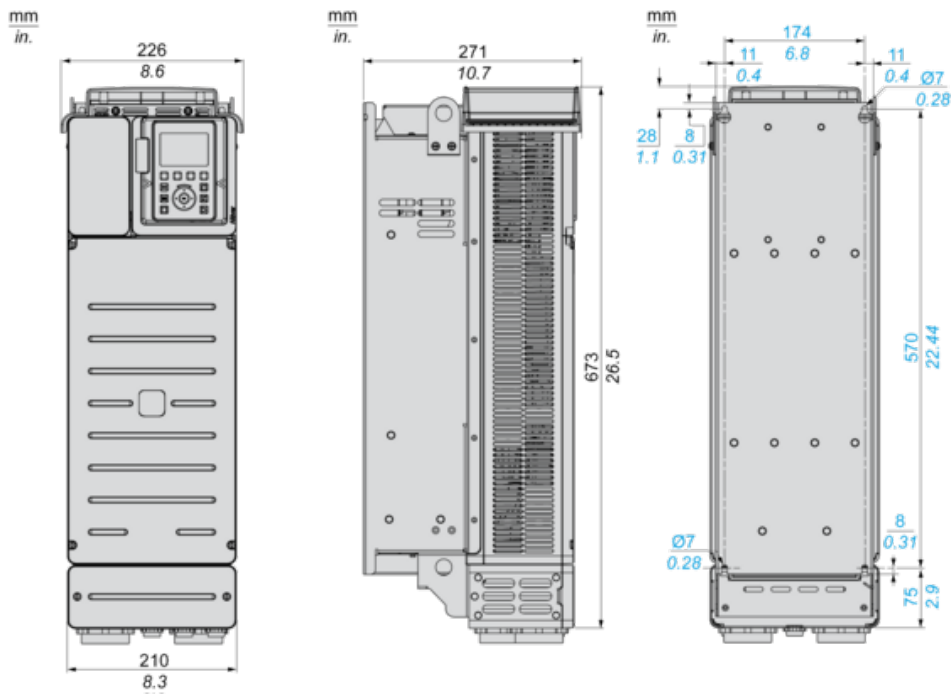

**Clearances**

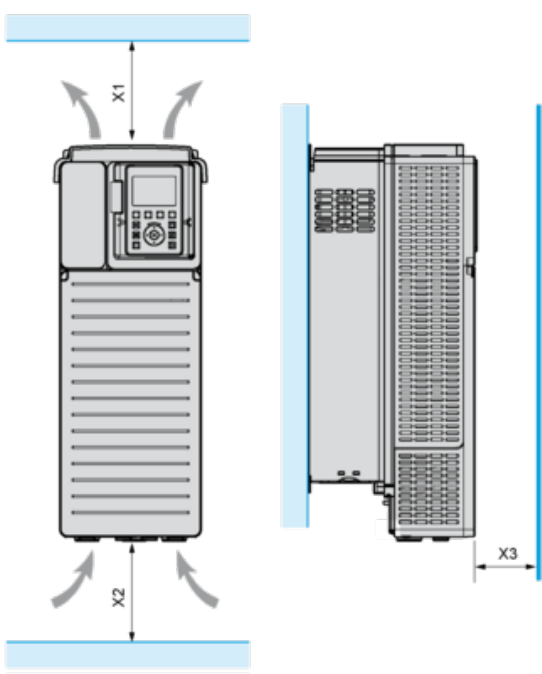

X1	X2	X3
≥ 100 mm (3.94 in.)	≥ 100 mm (3.94 in.)	≥ 10 mm (0.39 in.)

- Mount the device in a vertical position ( $\pm 10^\circ$ ). This is required for cooling the device.
- Do not mount the device close to heat sources.
- Leave sufficient free space so that the air required for cooling purposes can circulate from the bottom to the top of the drive.



**Mounting Types**

---

**Mounting Type A: Individual IP21**

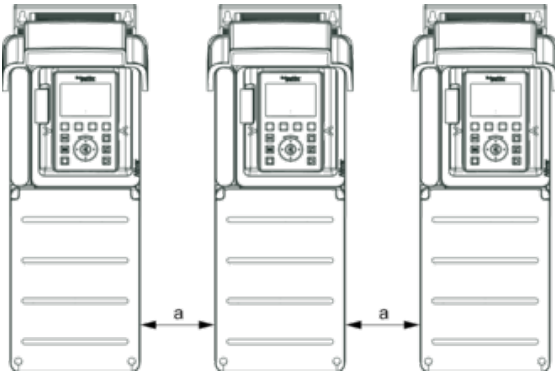

$a \geq 110 \text{ mm (4.33 in.)}$

**Mounting Type B: Side by Side IP20 (Possible, 2 Drives Only)**

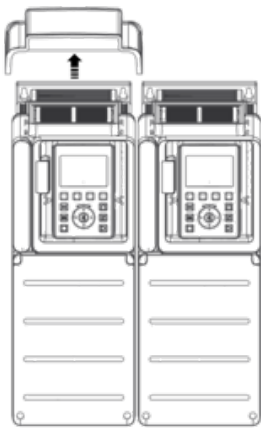

**Mounting Type C: Individual IP20**

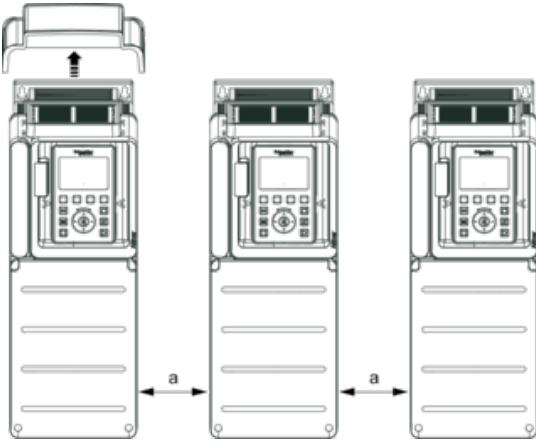

$a \geq 110 \text{ mm (4.33 in.)}$

**Three-Phase Power Supply with Upstream Breaking via Line Contactor**

Connection diagrams conforming to standards EN 954-1 category 1 and IEC/EN 61508 capacity SIL1, stopping category 0 in accordance with standard IEC/EN 60204-1

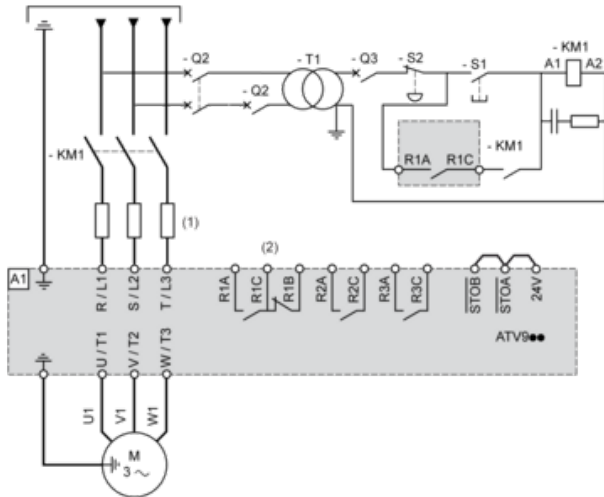

(1) Line choke if used

(2) Use relay R1 set to operating state Fault to switch Off the product once an error is detected.

**A1** : Drive

**KM1** : Line Contactor

**Q2, Q3** : Circuit breakers

**S1, S2** : Pushbuttons

**T1** : Transformer for control part

**Three-Phase Power Supply with Downstream Breaking via Contactor**

Connection diagrams conforming to standards EN 954-1 category 1 and IEC/EN 61508 capacity SIL1, stopping category 0 in accordance with standard IEC/EN 60204-1

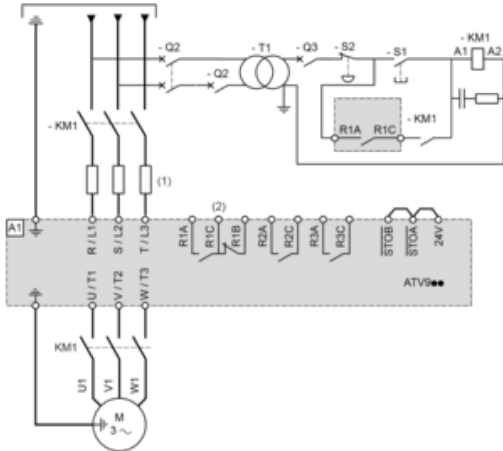

(1) Line choke if used

(2) Use relay R1 set to operating state Fault to switch Off the product once an error is detected.

A1 : Drive

KM1 : Contactor

**Control Block Wiring Diagram**

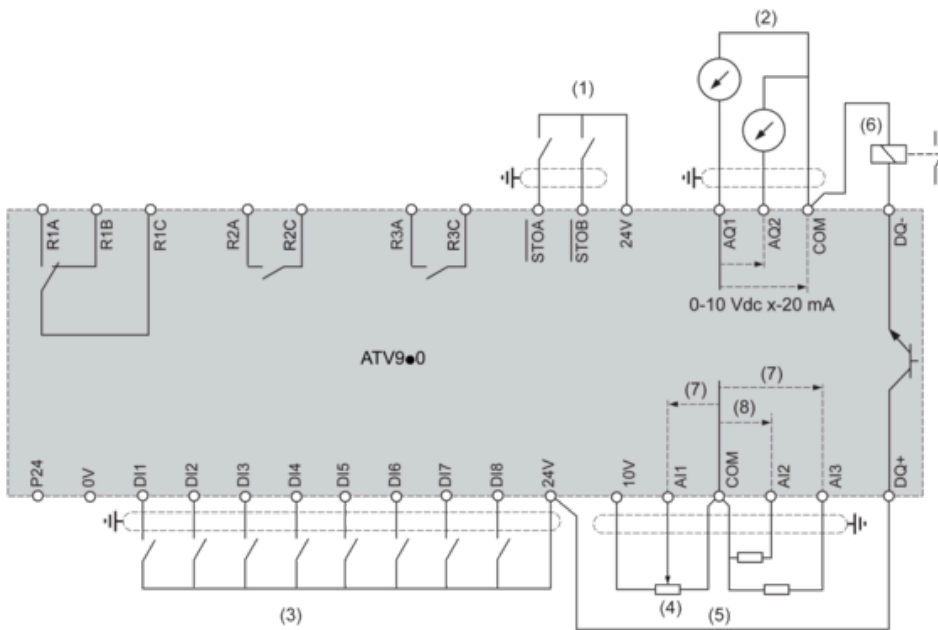

- (1) Safe Torque Off
  - (2) Analog Output
  - (3) Digital Input
  - (4) Reference potentiometer
  - (5) Analog Input
  - (6) Digital Output
  - (7) 0-10 Vdc, x-20 mA
  - (8) 0-10 Vdc, -10 Vdc...+10 Vdc
- R1A, R1B, R1C** : Fault relay  
**R2A, R2C** : Sequence relay  
**R3A, R3C** : Sequence relay

**Sensor Connection**

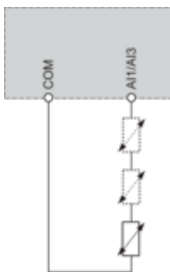

It is possible to connect either 1 or 3 sensors on terminals AI1 or AI3

**Sink / Source Switch Configuration**

The switch is used to adapt the operation of the logic inputs to the technology of the programmable controller outputs.

- Set the switch to Source (factory setting) if using PLC outputs with PNP transistors.
- Set the switch to Ext if using PLC outputs with NPN transistors.

**Switch Set to SRC (Source) Position Using the Output Power Supply for the Digital Inputs**

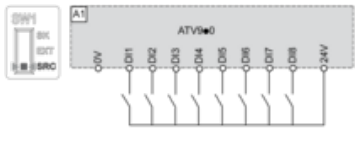

**Switch Set to SRC (Source) Position and Use of an External Power Supply for the DIs**

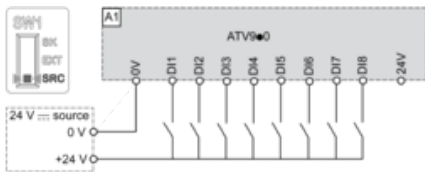

**Switch Set to SK (Sink) Position Using the Output Power Supply for the Digital Inputs**

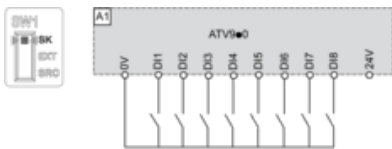

**Switch Set to EXT Position Using an External Power Supply for the DIs**

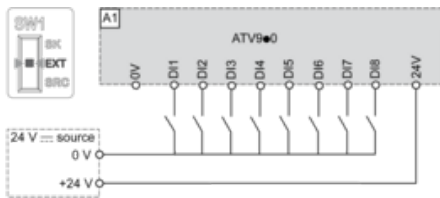

Derating Curves

---

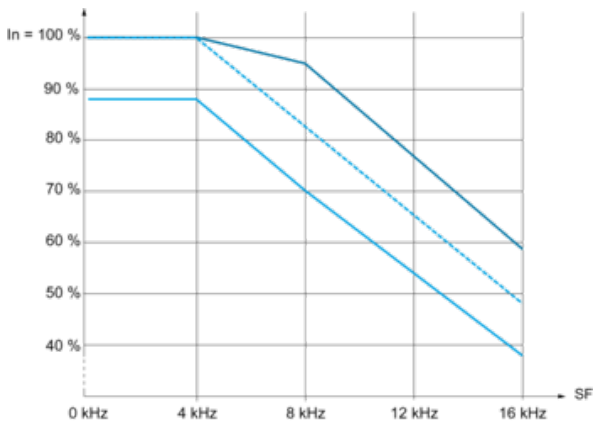

- 40 °C (104 °F) - Mounting type A, B and C
- - - 50 °C (122 °F) - Mounting type A, B and C
- 60 °C (140 °F) - Mounting type B and C

In : Nominal Drive Current

SF : Switching Frequency