

DWZ12D2/D4 DWZ15D2/D4

DWZ series subwoofer

Features:

- Heavy guage die cast basket;
- Kevlar added reinforced non-press paper cone;
- Red stitched ribbed EROM foam surround;
- 3" 4-layer copper wire voice coil;
- Reliable black poly-cotton 3-pc spiders system;
- Triple stacked 225oz Strontium magnets;
- Direct VC cooling motor design;
- Chrome push terminals;
- Rubber magnet boot and rubber gasket;
- Dual 2-ohm (D2) and dual 4-ohm (D4) Impedance;
- 1500W RMS power and 3000W MAX power

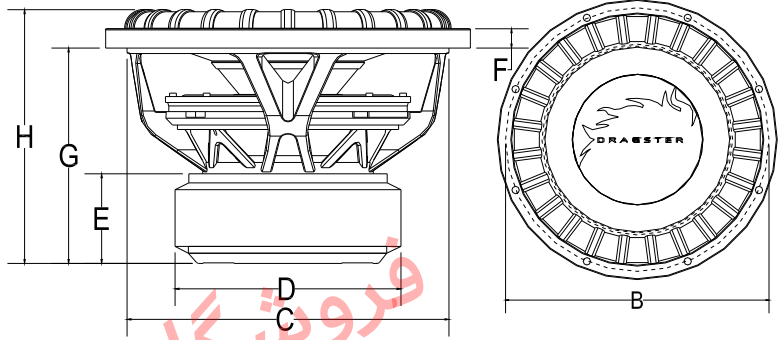

DWZ series DIMENSIONS

Dimensions	Value	DWZ12D2/D4	DWZ15D2/D4
Diameter A	mm	325	395
Diameter B	mm	303	375
Diameter C	mm	288	350
Diameter D	mm	196	196
Depth E	mm	89	89
Depth F	mm	15	16
Depth G	mm	198	212
Depth H	mm	235	252
Vd	L	5.8	7.7

DWZ series subwoofers T/S Parameters

MODEL	Imp ohm	Dcr ohm	Fs Hz	SD msqM	BL Tm	Qms	Qes	Qts	n %	SPLo dB	Vas L	Cms µm/N	Mms g	Mmd g	Xmax mm	Vd L
DWZ12D2	1	0.9	29.1	51.07	12.23	4.136	4.136	0.316	0.291	86.7	38.47	103.86	287.1	280.5	15	5.8
DWZ12D2	4	3.8	29.0	51.07	24.81	4.023	0.328	0.304	0.274	86.4	38.19	103.12	291.9	285.3	16	5.8
DWZ12D4	2	1.7	30.2	51.07	15.76	3.710	0.330	0.303	0.327	87.2	40.45	109.21	254.1	247.4	16	5.8
DWZ12D4	8	6.8	29.4	51.07	34.56	3.623	0.293	0.271	0.326	87.2	38.94	105.14	268.9	252.2	16	5.8
DWZ15D2	1	0.9	31.6	77.93	13.20	4.815	0.324	0.304	0.652	90.2	69.34	80.41	316.0	303.5	16	7.7
DWZ15D2	4	3.8	30.7	77.93	31.37	4.037	0.263	0.247	0.697	90.4	68.83	79.33	333.5	321.0	16	7.7
DWZ15D4	2	1.7	29.2	77.93	14.88	4.297	0.402	0.367	0.504	89.3	73.88	82.22	284.8	272.3	16	7.7
DWZ15D4	8	6.8	29.2	77.93	34.81	4.259	0.368	0.339	0.511	89.4	72.44	84.00	302.0	289.5	16	7.7

*Above parameters are tested after each subwoofer was break-ined under 1500W(50Hz) power for 3hours.

*Due to continuous pursuit of performance, specifications change without prior notice.