

**YD10 Series Converter**

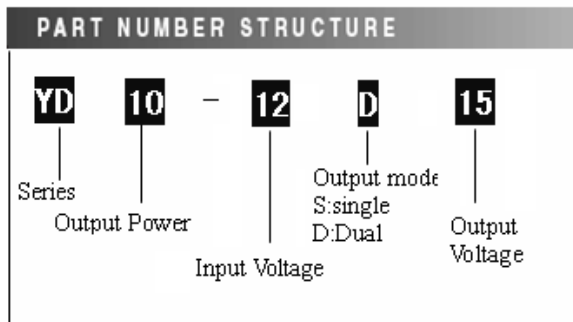

**Features**

1 inch × 2inch. Standard Size

High Efficiency

1500Vdc Isolation Voltage

Applications: Telecommunication equipments\data exchange servers and distributed power..

**Outline Diagram**

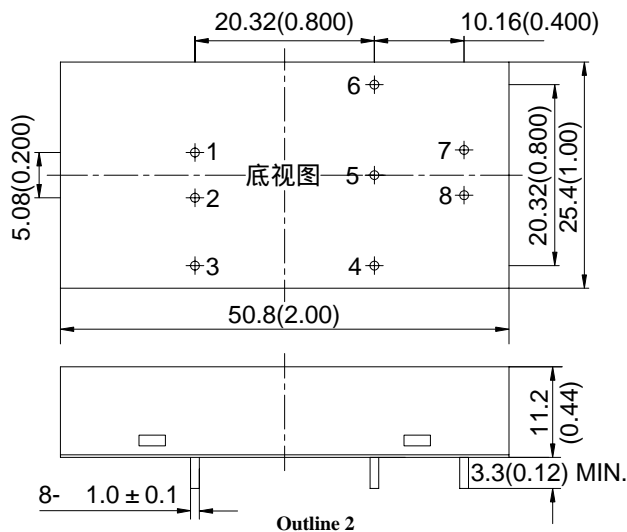
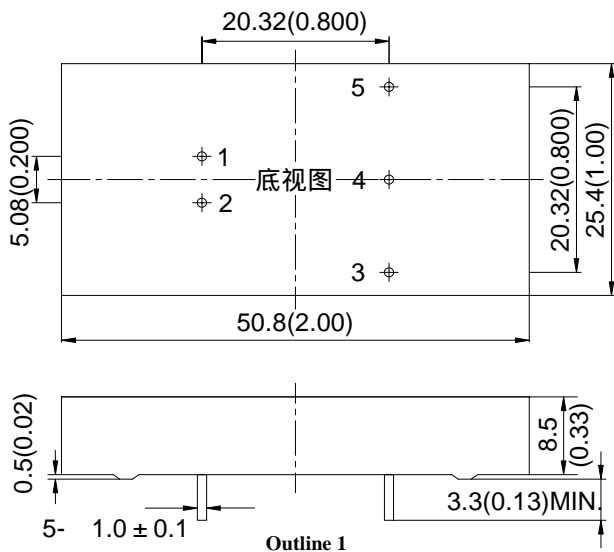

Pin	Sign	Function
1	+V <sub>in</sub>	Positive Input Voltage
2	-V <sub>in</sub>	Negative Input Voltage
3	-V <sub>O</sub>	Negative Output Voltage; Output Voltage Dual
4	NP	No Pin; Component Object Model
5	+V <sub>O</sub>	Positive Output Voltage; Output Voltage Single

Case material: Aluminum,black;  
Pin: copper with gold plating  
Notes: all dimensions in mm(inches)  
Tolerance: X.X±0.5(X.XX±0.02)  
X.XX±0.25(X.XXX±0.010)

Pin	Sign	Function
1	+V <sub>in</sub>	Positive Input Voltage
2	-V <sub>in</sub>	Negative Input Voltage
4	-V <sub>O</sub>	Negative Output Voltage; Output Voltage Dual
6	+V <sub>O</sub>	Positive Output Voltage; Output Voltage Single
3/5	NP	No Pin; Component Object Model
7/8	NP	

Case material: Aluminum,black;  
Pin: copper with gold plating  
Notes: all dimensions in mm(inches)  
Tolerance: X.X±0.5(X.XX±0.02)  
X.XX±0.25(X.XXX±0.010)

**Performance Specifications And Ordering Guide**

Unless otherwise specified, all values are given at: 25 °C, one standard atmosphere pressure, pure resistive load and basic connection.

Model	Output			Capacitive load(μF)	Input Range-DC (Volts)	Efficiency (%)	Outline
	Voltage(V)	Current(A)	Ripple and Noise (mV)				
YD10-12S12	12	0.84	100	2200	9-18	75	1
YD10-12S24	24	0.42	200	1000	9-18	79	1
YD10-24S05	5.05	2	130	4700	18-36	78	1
YD10-24S12	12	0.84	100	2200	18-36	80	1
YD10-24S15	15	0.67	100	1000	18-36	81	1
YD10-48S03	3.3	2.5	160	10000	36-72	74	1
YD10-48S05	50.5	2	100	4700	36-72	80	1
YD10-48S12	12	0.84	100	2200	36-72	82	1
YD10-48S15	15	0.67	100	2200	36-72	84	1
YD10-48S24	24	0.42	100	470	36-72	80	1
YD10-110S12	12	0.84	200	1000	66-160	82	2
YD10-110S24	24	0.42	200	220	66-160	80	2

**Performance/Functional Specifications**

Input	
<b>Input Voltage:</b>	See Ordering Guide
Output	
<b>Voltage Accuracy:</b>	±1%
<b>Line Regulation:</b>	±0.2%max.
<b>Load Regulation:</b>	±0.5%max.
<b>Ripple and Noise:</b>	50mVp-p Vo 5Vdc 100 mVp-p Other 200 mVp-p Vo 48Vdc
<b>Efficiency:</b>	See Ordering Guide
<b>Transient Response Recovery Time(μs):</b>	See respective data sheet
<b>Transient Response Voltage Deviation(%):</b>	See respective data sheet
<b>Start-up Delay Time:</b>	See respective data sheet
<b>Rise Time:</b>	See respective data sheet

General	
<b>Isolation Voltage:</b>	1500Vdc /1min/1mA (Input-Output)
<b>Switching Frequency:</b>	300kHz typ.
<b>MTBF :</b>	2×10 <sup>6</sup> h(Bellcore TR332, 25 °C)
<b>Temperature Coefficient:</b>	±0.02% per °C (Max)
<b>Case Temperature:</b>	-25 ~ +95 (Industry)
<b>Storage Temperature:</b>	-55 ~ +125
<b>Relative Humidity:</b>	10%~90%
<b>Short-circuit Protection:</b>	Continuous, Automatic Recovery
<b>Isolation Resistance:</b>	50 MΩmin(500Vdc,90%RH)
<b>Manual Soldering:</b>	425 max (5s Max)
<b>Wave Soldering:</b>	255 max (10s Max)
<b>Weight:</b>	10g~30g

Characteristic Curves

Efficiency

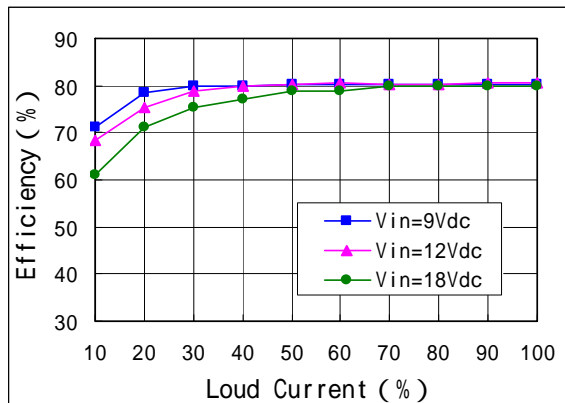

YD10-12S12

Efficiency

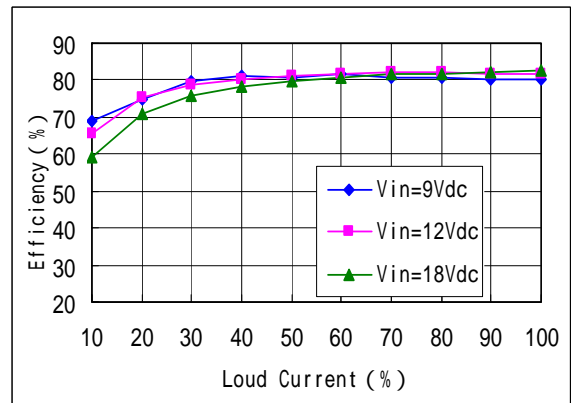

YD10-12S24

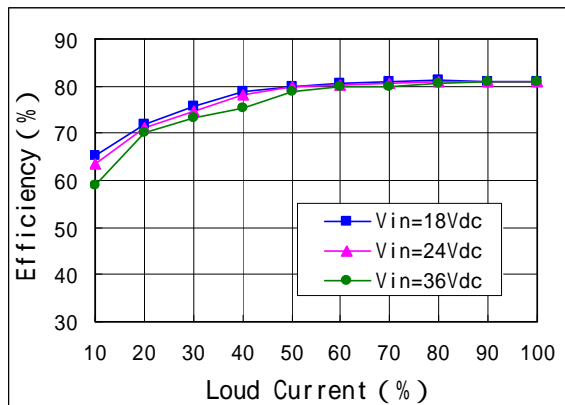

YD10-24S05

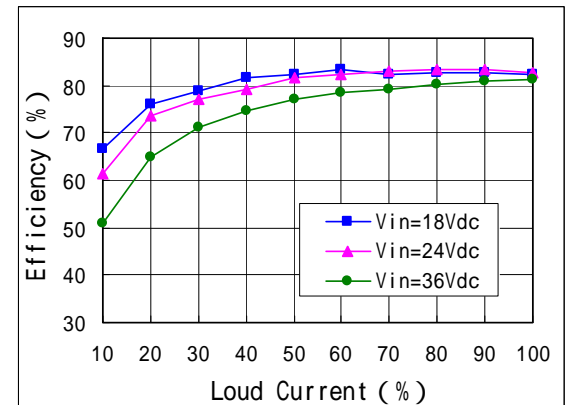

YD10-24S12

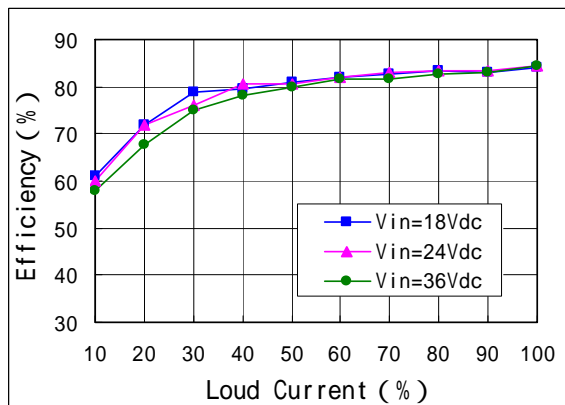

YD10-24S15

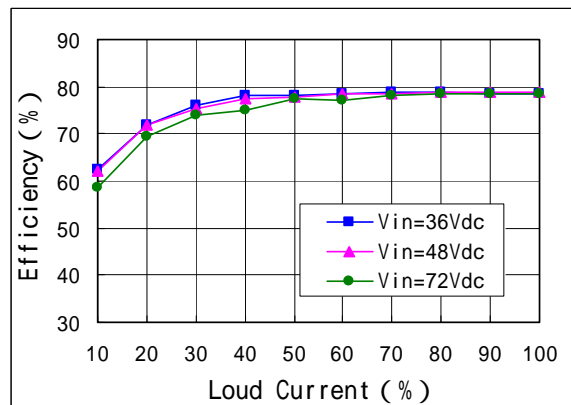

YD10-48S03

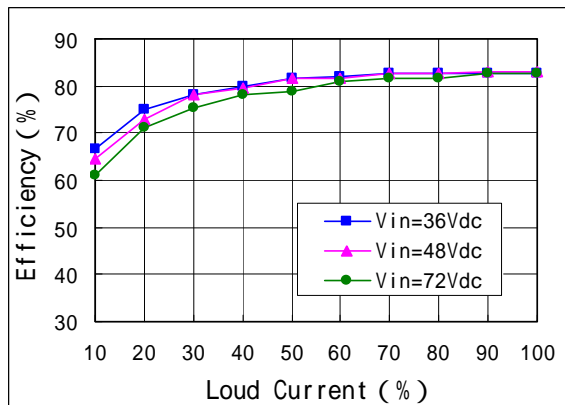

YD10-48S05

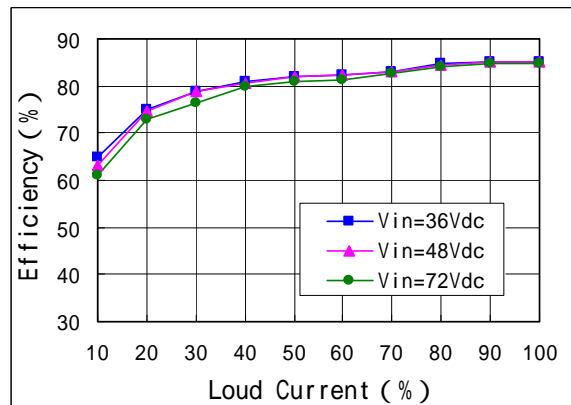

YD10-48S12

**Efficiency**

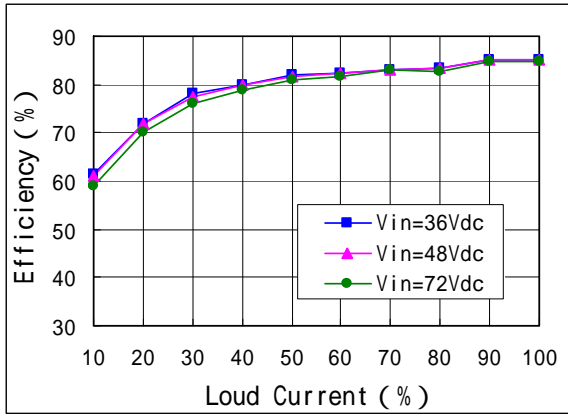

YD10-48S15

**Efficiency**

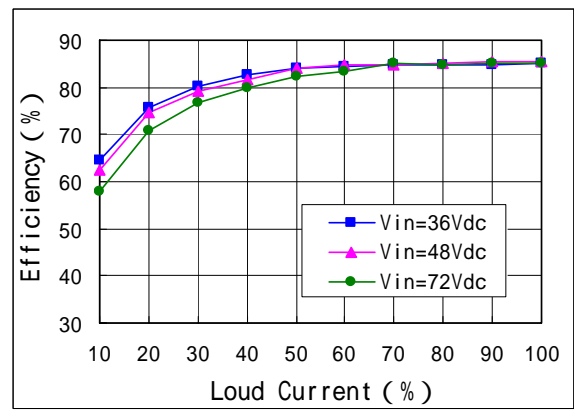

YD10-48S24

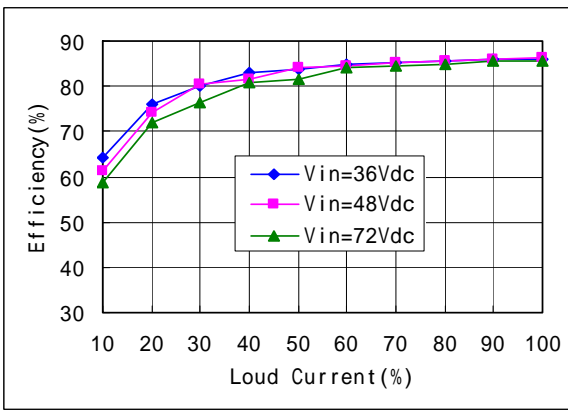

YD10-48S48

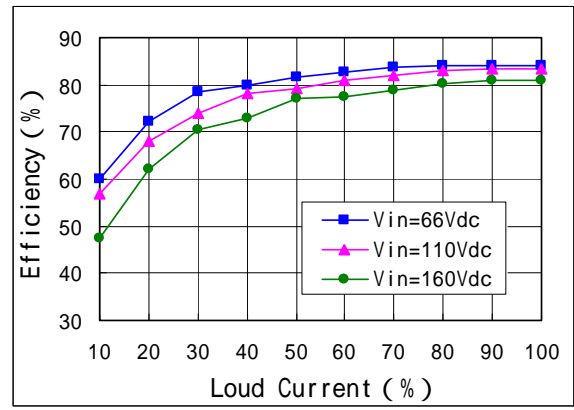

YD10-110S12

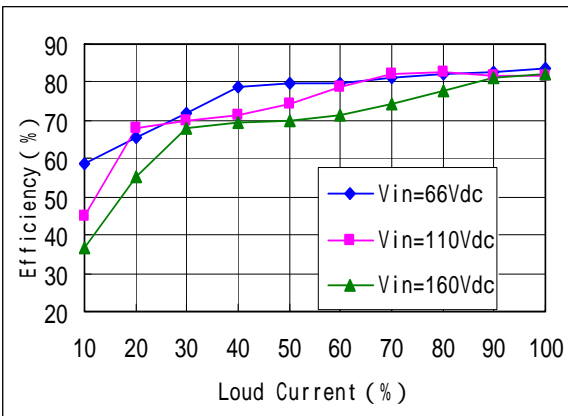

YD10-110S24

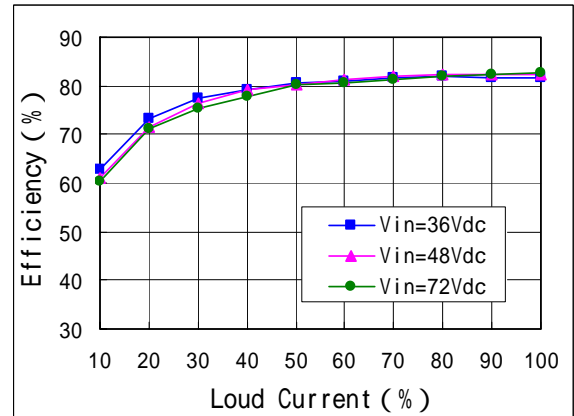

YD10-48D05

**Derating**

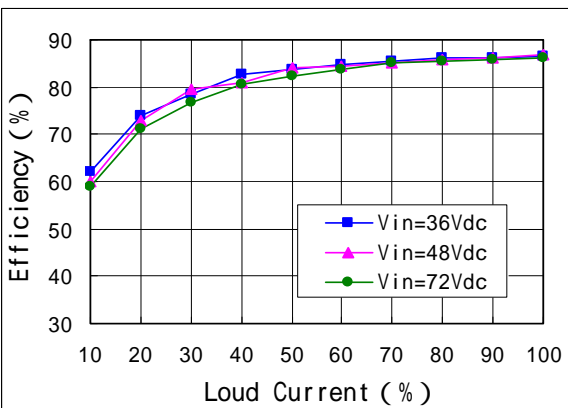

YD10-48D15

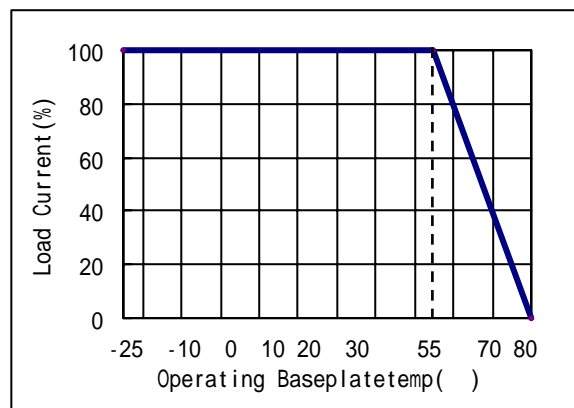

**Design Considerations**

**Basic Connection**

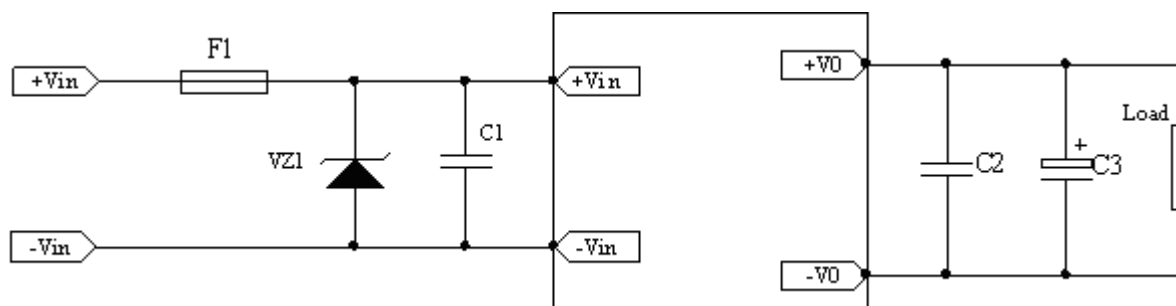

**Notes :**

1. Please refer to the respective data sheet for further information.
2. F1: fuse ; VZ1: TVS; C1:22μF~220μF , C2: 1μF~22μF ; C3: 10μF~1000μF。

**Recommended Layout**

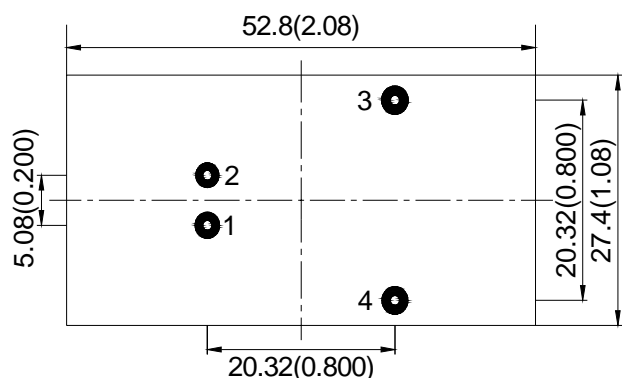

No.	Recommendation & Notes
Pad Design	Pad holes 1 ~ 4:1.2mm , pad diameter including hol:2.5mm
Mounting Direction	heatsink face up, for natural convection
Safety	Isolated Converters, care to the spacing between input and output
Electrical	The Vin(-) and Vo(-) planes should be placed under of the converter separately. Avoid routing sensitive signal or high disturbance AC signal under the converter

**External Capacitance**

Unless special purpose (i.e. prolonging hold-up time, input impedance matching), the recommended input filter’s capacitance ranges 22μF to 220μF, which not only offers a stable system, and reduces the cost, but also lessens the inrush current when the power supplies.

When larger capacitance is required, a circuit of suppressing the inrush current is recommended when the regulator start-up and a discharge circuit is recommended when the output dropped, ensuring the reliability and safety of other equipments in the system.

**Thermal Consideration**

The converters operate in a variety of thermal environments; however, sufficient cooling should be provided to ensure reliable operation of the unit. Heat is removed by conduction, convection and radiation to the surrounding environment.

When case temperature is higher than the permitted operating, the derating curves should be referred or external heat dissipation measures. Forced air cooling

or heatsink, should be used. The air tunnel should be considered for forced air cooling, to avoid heated air be hindered or forming swirl; when heatsink used, it should be attached the converter closely, through double-side thermal conductivity insulation adhesive or thermal conductivity silicone for heat exchange.

**Series and Parallel Operation**

The converters should not be paralleled directly to increase power, but they can be paralleled each other through o-ring switches or diodes. Make sure that every converter’s maximum load current should not exceed the rated current at anytime if they are paralleled without using external current sharing circuits. The converters can operate in series. To prevent against start-up failure due to start up time difference, SBD with low voltage difference can be paralleled at the output pins(SBD negative terminal connect to the positive pin of the output) for each converter.

**Safety Consideration**

The module, as one component for the end user, should be installed into the equipment. It is required to meet safety requirements in the system design.

To avoiding fire and be protected when short circuit occurred, it is recommended that a fast blow fuse with rating 2.5 to 3 times of converter's continuous input peak current is used in series at the input terminal.(Inrush current suppression circuit is required for greater filter capacitance at input terminal, or it will result in the misoperation of the fuse ).

**Delivery Package Information**

Package material is multiple wall corrugated with less than  $10^{12} \Omega$  surface resistance; internal material is anti-static foam with less than  $10^5 \Omega$  surface resistance. Tray capacity: 32 PCS/box , Tray weight: 0.7kg~0.9kg; Carton capacity:15×32=480 PCS, Carton weight:11.0kg~14.0kg.

**Quality Statement**

The modules are manufactured in accordance with ISO 9001 system requirements, in compliant with YD/T1376-2005, andn are monitored 100% by auto-testing system, 100% burn in.

The warranty for the modules is 5-year.

**Contact Information**

---

Anhui Hesion Trading Co.,Ltd.

Add: Room1001,Zheshang Business Mansion,  
No.103 Kexue Road, Hefei Anhui,China 230088

TEL: +86-551-5369069,5369067

FAX:+86-551-5369070

Email: [alecz@ahhesion.com](mailto:alecz@ahhesion.com)

Backup:alecz@126.com

Web: [www.yihongtai.com](http://www.yihongtai.com)