

PALCE16V8 Family

EE CMOS 20-Pin Universal Programmable Array Logic

Advanced
Micro
Devices

DISTINCTIVE CHARACTERISTICS

- Pin, function and fuse-map compatible with all 20-pin GAL[®] devices
- Electrically erasable CMOS technology provides reconfigurable logic and full testability
- High-speed CMOS technology
 - 7.5 ns propagation delay for "-7" version
 - 10 ns propagation delay for "-10" version
 - 15 ns propagation delay for "-15" version
- Direct plug-in replacement for the PAL16R8 series and most of the PAL10H8 series
- Outputs programmable as registered or combinatorial in any combination
- Programmable output polarity
- Programmable enable/disable control
- Preloadable output registers for testability
- Automatic register reset on power up
- Cost-effective 20-pin plastic DIP, PLCC, and SOIC packages
- Extensive third-party software and programmer support through FusionPLD partners
- Fully tested for 100% programming and functional yields and high reliability

GENERAL DESCRIPTION

The PALCE16V8 is an advanced PAL device built with low-power, high-speed, electrically-erasable CMOS technology. It is functionally compatible with all 20-pin GAL devices. The macrocells provide a universal device architecture. The PALCE16V8 will directly replace the PAL16R8 and PAL10H8 series devices, with the exception of the PAL16C1.

The PALCE16V8 utilizes the familiar sum-of-products (AND/OR) architecture that allows users to implement complex logic functions easily and efficiently. Multiple levels of combinatorial logic can always be reduced to sum-of-products form, taking advantage of the very wide input gates available in PAL devices. The equations are programmed into the device through floating-gate cells in the AND logic array that can be erased electrically.

The fixed OR array allows up to eight data product terms per output for logic functions. The sum of these products

feeds the output macrocell. Each macrocell can be programmed as registered or combinatorial with an active-high or active-low output. The output configuration is determined by two global bits and one local bit controlling four multiplexers in each macrocell.

AMD's FusionPLD program allows PALCE16V8 designs to be implemented using a wide variety of popular industry-standard design tools. By working closely with the FusionPLD partners, AMD certifies that the tools provide accurate, quality support. By ensuring that third-party tools are available, costs are lowered because a designer does not have to buy a complete set of new tools for each device. The FusionPLD program also greatly reduces design time since a designer can use a tool that is already installed and familiar. Please refer to the PLD Software Reference Guide for certified development systems and the Programmer Reference Guide for approved programmers.

BLOCK DIAGRAM

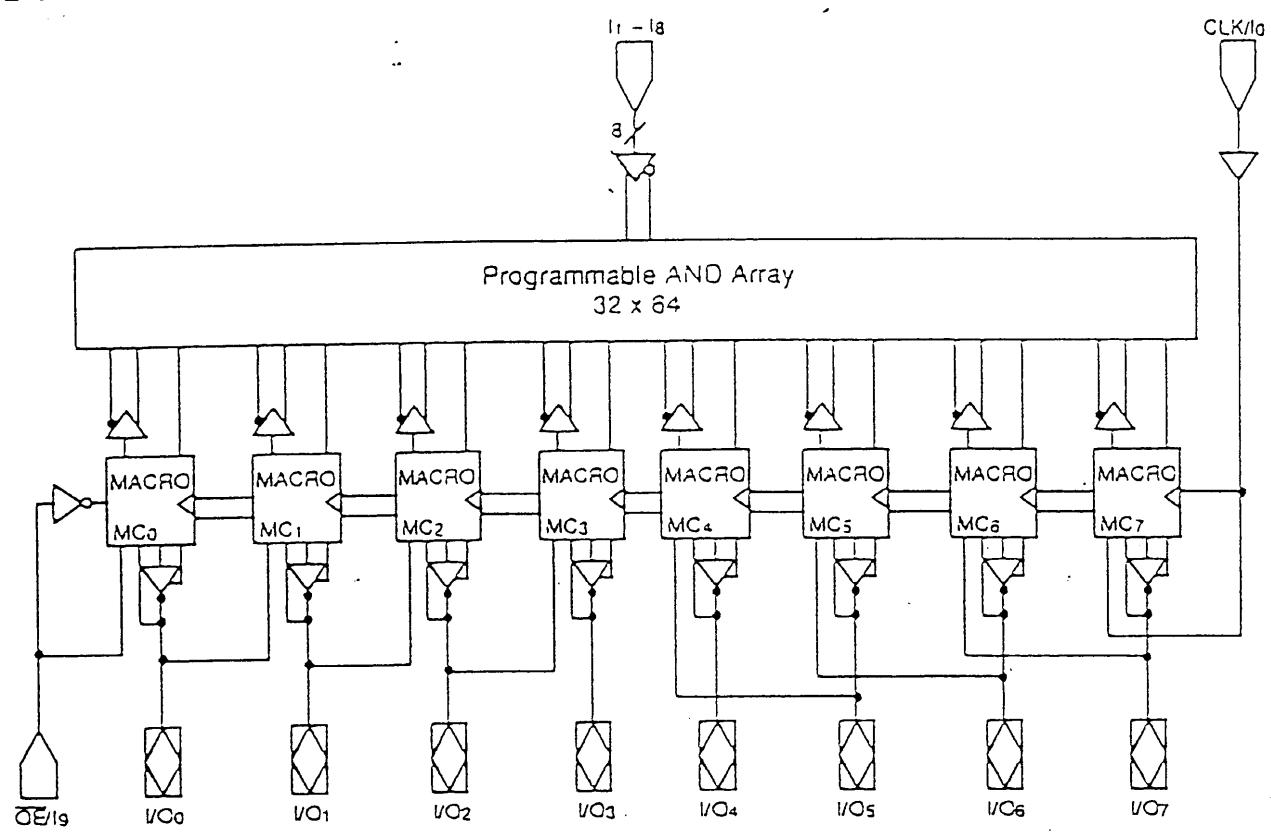

12197-0018

CONNECTION DIAGRAMS Top View

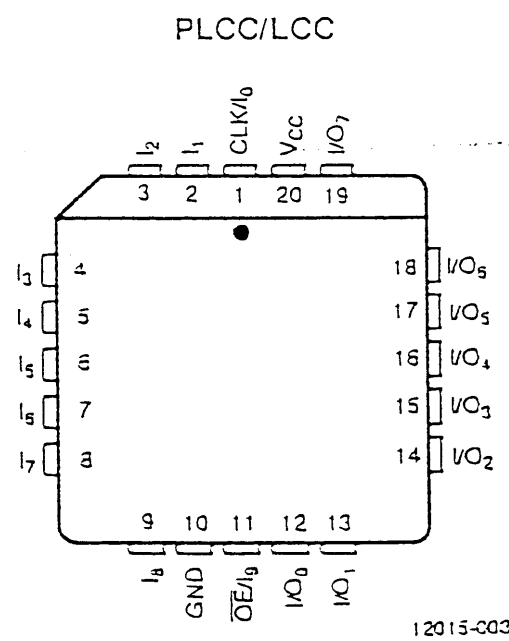
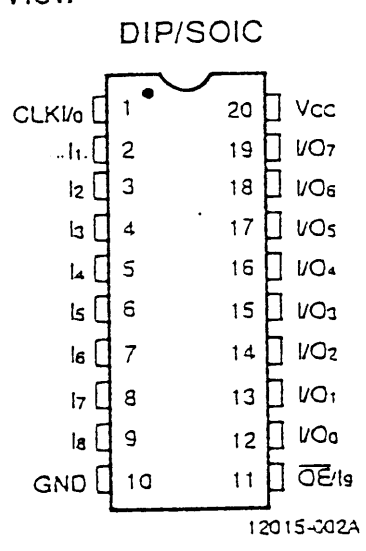

Note: Pin 1 is marked for orientation

PIN DESIGNATIONS

- CLK = Clock
- GND = Ground
- I = Input
- I/O = Input/Output
- OE = Output Enable
- Vcc = Supply Voltage



ORDERING INFORMATION

Commercial Products

AMD programmable logic products for commercial applications are available with several ordering options. The order number (Valid Combination) is formed by a combination of:

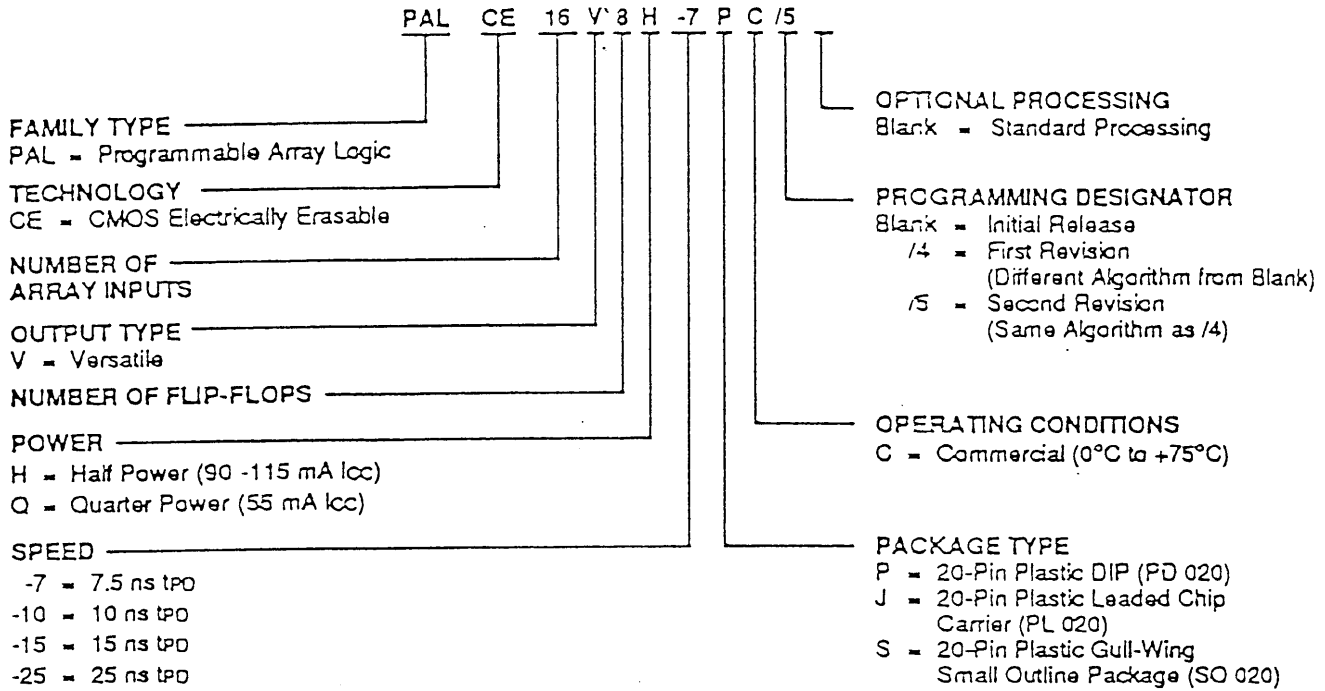

Valid Combinations		
PALCE16V8H-7	PC, JC	/5
PALCE16V8H-10	PC, JC, SC	/4, /5
PALCE16V8H-15	PC, JC, SC	Blank, /4
PALCE16V8H-25		
PALCE16V8Q-15	PC, JC	
PALCE16V8Q-25		

Valid Combinations

The Valid Combinations table lists configurations planned to be supported in volume for this device. Consult the local AMD sales office to confirm availability of specific valid combinations and to check on newly released combinations.

Note: Marked with AMD logo.

ORDERING INFORMATION

APL Products (Military)

AMD programmable logic products for Aerospace and Defense applications are available with several ordering options. APL (Approved Products List) products are fully compliant with MIL-STD-883 requirements. The order number (Valid Combination) is formed by a combination of:

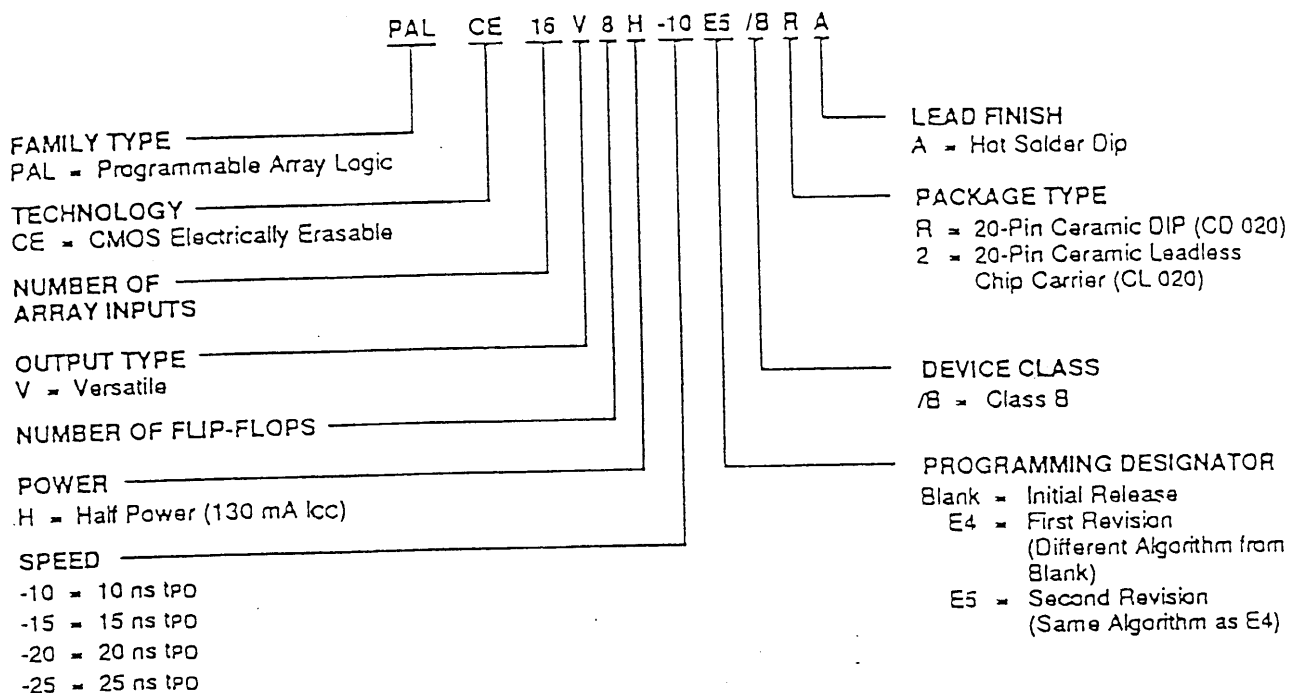

Valid Combinations		
PALCE16V8H-10	E5	/BRA /B2A
PALCE16V8H-15	E4, E5	
PALCE16V8H-20	Blank, E4	
PALCE16V8H-25		

Valid Combinations

The Valid Combinations table lists configurations planned to be supported in volume for this device. Consult the local AMD sales office to confirm availability of specific valid combinations, to check on newly released combinations and to obtain additional data on AMD's standard military grade products.

Note: Marked with AMD logo.

Group A Tests

Group A tests consist of Subgroups 1, 2, 3, 7, 8, 9, 10, 11.

Military Burn-in

Military burn-in is in accordance with the current revision of MIL-STD-883, Test Method 1015, Conditions A through E. Test conditions are selected at AMD's option.

FUNCTIONAL DESCRIPTION

The PALCE16V8 is a universal PAL device. It has eight independently configurable macrocells (MC₀–MC₇). Each macrocell can be configured as registered output, combinatorial output, combinatorial I/O or dedicated input. The programming matrix implements a programmable AND logic array, which drives a fixed OR logic array. Buffers for device inputs have complementary outputs to provide user-programmable input signal polarity. Pins 1 and 11 serve either as array inputs or as clock (CLK) and output enable (OE), respectively, for all flip-flops.

Unused input pins should be tied directly to V_{CC} or GND. Product terms with all bits unprogrammed (disconnected) assume the logical HIGH state and product terms with both true and complement of any input signal connected assume a logical LOW state.

The programmable functions on the PALCE16V8 are automatically configured from the user's design speci-

fication, which can be in a number of formats. The design specification is processed by development software to verify the design and create a programming file. This file, once downloaded to a programmer, configures the device according to the user's desired function.

The user is given two design options with the PALCE16V8. First, it can be programmed as a standard PAL device from the PAL16R8 and PAL10H8 series. The PAL programmer manufacturer will supply device codes for the standard PAL device architectures to be used with the PALCE16V8. The programmer will program the PALCE16V8 in the corresponding architecture. This allows the user to use existing standard PAL device JEDEC files without making any changes to them. Alternatively, the device can be programmed as a PALCE16V8. Here the user must use the PALCE16V8 device code. This option allows full utilization of the macrocell.

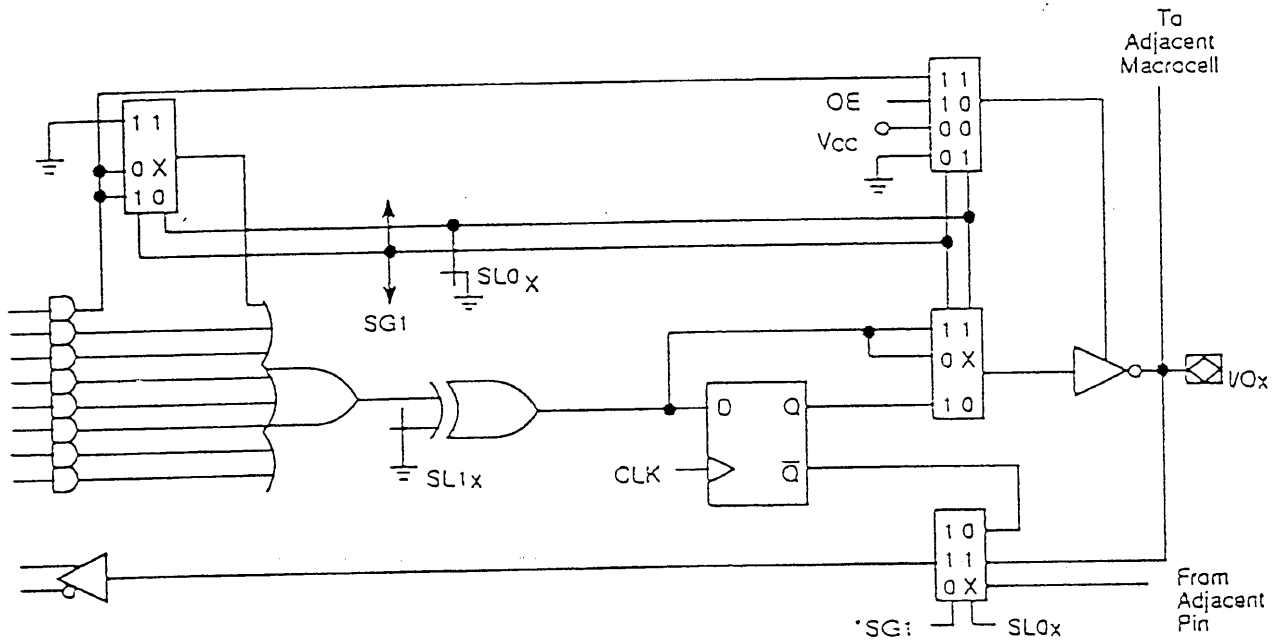

*In macrocells MC₀ and MC₇, SG₁ is replaced by $\overline{SG_0}$ on the feedback multiplexer.

144G8C-001A

PALCE16V8 Macrocell

Configuration Options

Each macrocell can be configured as one of the following: registered output, combinatorial output, combinatorial I/O, or dedicated input. In the registered output configuration, the output buffer is enabled by the \overline{OE} pin. In the combinatorial configuration, the buffer is either controlled by a product term or always enabled. In the dedicated input configuration, it is always disabled. With the exception of MC_0 and MC_7 , a macrocell configured as a dedicated input derives the input signal from an adjacent I/O. MC_0 derives its input from pin 11 (\overline{OE}) and MC_7 from pin 1 (CLK).

The macrocell configurations are controlled by the configuration control word. It contains 2 global bits (SG0 and SG1) and 16 local bits (SL0₀ through SL0₇ and SL1₀ through SL1₇). SG0 determines whether registers will be allowed. SG1 determines whether the PALCE16V8 will emulate a PAL16R8 family or a PAL10H8 family device. Within each macrocell, SL0_x, in conjunction with SG1, selects the configuration of the macrocell, and SL1_x sets the output as either active low or active high for the individual macrocell.

The configuration bits work by acting as control inputs for the multiplexers in the macrocell. There are four multiplexers: a product term input, an enable select, an output select, and a feedback select multiplexer. SG1 and SL0_x are the control signals for all four multiplexers. In MC_0 and MC_7 , $\overline{SG0}$ replaces SG1 on the feedback multiplexer. This accommodates CLK being the adjacent pin for MC_7 and \overline{OE} the adjacent pin for MC_0 .

Registered Output Configuration

The control bit settings are SG0 = 0, SG1 = 1 and SL0_x = 0. There is only one registered configuration. All eight product terms are available as inputs to the OR gate. Data polarity is determined by SL1_x. The flip-flop is loaded on the LOW-to-HIGH transition of CLK. The feedback path is from \overline{Q} on the register. The output buffer is enabled by \overline{OE} .

Combinatorial Configurations

The PALCE16V8 has three combinatorial output configurations: dedicated output in a non-registered device, I/O in a non-registered device and I/O in a registered device.

Dedicated Output In a Non-Registered Device

The control bit settings are SG0 = 1, SG1 = 0 and SL0_x = 0. All eight product terms are available to the OR gate. Although the macrocell is a dedicated output, the feedback is used, with the exception of pins 15 and 16. Pins 15 and 16 do not use feedback in this mode. Because CLK and \overline{OE} are not used in a non-registered device, pins 1 and 11 are available as input signals. Pin 1 will use the feedback path of MC_7 and pin 11 will use the feedback path of MC_0 .

Combinatorial I/O In a Non-Registered Device

The control bit settings are SG0 = 1, SG1 = 1, and SL0_x = 1. Only seven product terms are available to the OR gate. The eighth product term is used to enable the output buffer. The signal at the I/O pin is fed back to the AND array via the feedback multiplexer. This allows the pin to be used as an input.

Because CLK and \overline{OE} are not used in a non-registered device, pins 1 and 11 are available as inputs. Pin 1 will use the feedback path of MC_7 and pin 11 will use the feedback path of MC_0 .

Combinatorial I/O in a Registered Device

The control bit settings are SG0 = 0, SG1 = 1 and SL0_x = 1. Only seven product terms are available to the OR gate. The eighth product term is used as the output enable. The feedback signal is the corresponding I/O signal.

Dedicated Input Configuration

The control bit settings are SG0 = 1, SG1 = 0 and SL0_x = 1. The output buffer is disabled. Except for MC_0 and MC_7 the feedback signal is an adjacent I/O. For MC_0 and MC_7 the feedback signals are pins 1 and 11. These configurations are summarized in Table 1 and illustrated in Figure 2.

Table 1. Macrocell Configuration

SG0	SG1	SL0 _x	Cell Configuration	Devices Emulated
Device Uses Registers				
0	1	0	Registered Output	PAL16R8, 16R6, 16R4
0	1	1	Combinatorial I/O	PAL16R6, 16R4
Device Uses No Registers				
1	0	0	Combinatorial Output	PAL10H8, 12H6, 14H4, 16H2, 10L8, 12L6, 14L4, 16L2
1	0	1	Input	PAL12H6, 14H4, 16H2, 12L6, 14L4, 16L2
1	1	1	Combinatorial I/O	PAL16L8

Programmable Output Polarity

The polarity of each macrocell can be active-high or active-low, either to match output signal needs or to reduce product terms. Programmable polarity allows Boolean expressions to be written in their most compact form (true or inverted), and the output can still be of the desired polarity. It can also save "DeMorganizing" efforts.

Selection is through a programmable bit SL1_x which controls an exclusive-OR gate at the output of the AND/OR logic. The output is active high if SL1_x is 1 and active low if SL1_x is 0.

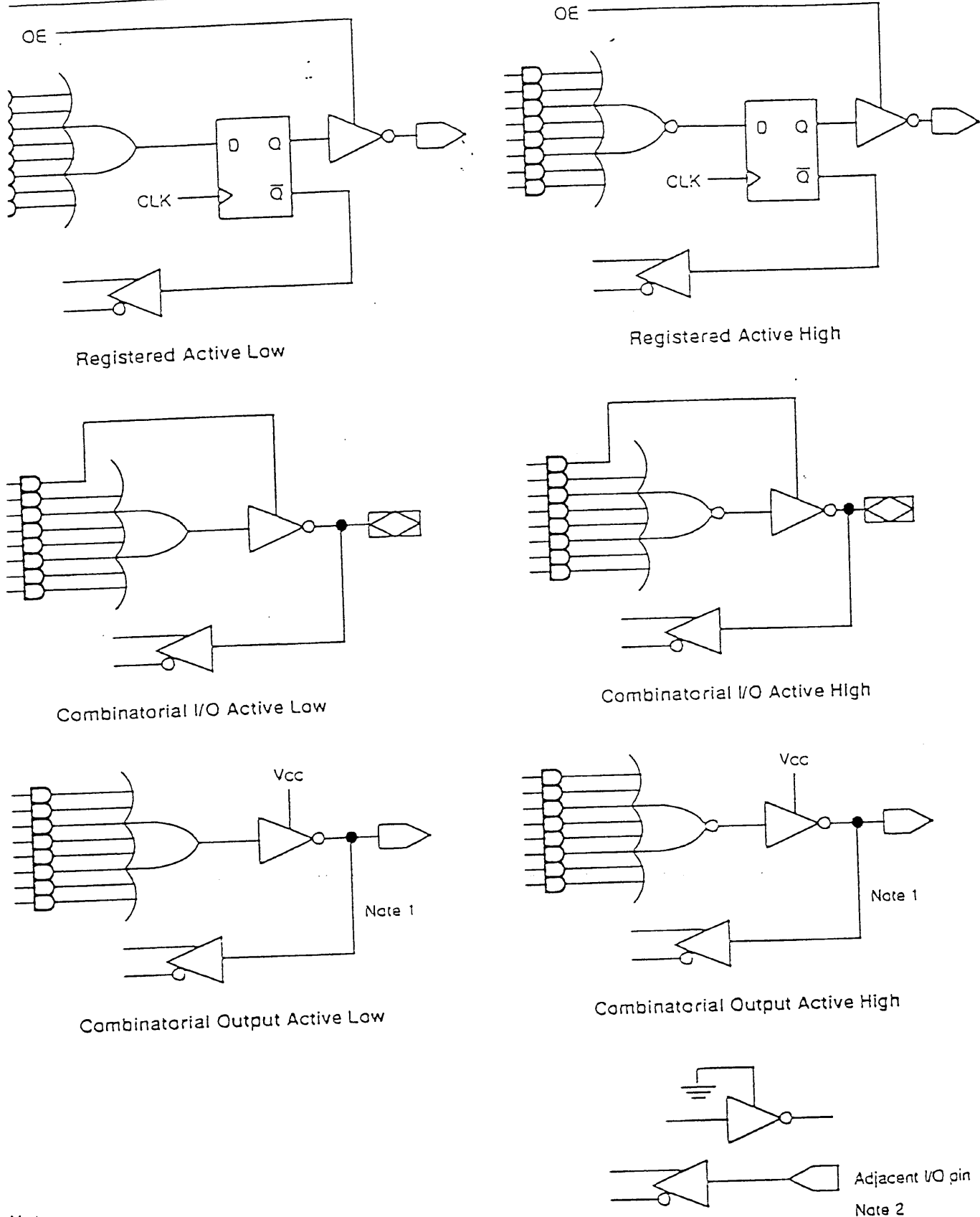

- Notes:
1. Feedback is not available on pins 15 and 16 in the combinatorial output mode.
 2. This configuration is not available on pins 15 and 16.

Dedicated Input Adjacent I/O pin
Note 2
14408C-002A

Figure 2. Macrocell Configurations

Power-Up Reset

All flip-flops power up to a logic LOW for predictable system initialization. Outputs of the PALCE16V8 will depend on whether they are selected as registered or combinatorial. If registered is selected, the output will be HIGH. If combinatorial is selected, the output will be a function of the logic.

Register Preload

The register on the PALCE16V8 can be preloaded from the output pins to facilitate functional testing of complex state machine designs. This feature allows direct loading of arbitrary states, making it unnecessary to cycle through long test vector sequences to reach a desired state. In addition, transitions from illegal states can be verified by loading illegal states and observing proper recovery.

Security Bit

A security bit is provided on the PALCE16V8 as a deterrent to unauthorized copying of the array configuration patterns. Once programmed, this bit defeats readback and verification of the programmed pattern by a device programmer, securing proprietary designs from competitors. The bit can only be erased in conjunction with the array during an erase cycle.

Electronic Signature Word

An electronic signature word is provided in the PALCE16V8 device. It consists of 64 bits of programmable memory that can contain user-defined data. The signature data is always available to the user independent of the security bit.

Programming and Erasing

The PALCE16V8 can be programmed on standard logic programmers. It also may be erased to reset a previously configured device back to its virgin state. Erasure is automatically performed by the programming hardware. No special erase operation is required.

Quality and Testability

The PALCE16V8 offers a very high level of built-in quality. The erasability of the device provides a direct means of verifying performance of all AC and DC parameters. In addition, this verifies complete programmability and functionality of the device to provide the highest programming yields and post-programming functional yields in the industry.

Technology

The high-speed PALCE16V8 is fabricated with AMD's advanced electrically erasable (EE) CMOS process. The array connections are formed with proven EE cells. Inputs and outputs are designed to be compatible with TTL devices. This technology provides strong input clamp diodes, output slew-rate control, and a grounded substrate for clean switching.

LOGIC DIAGRAM

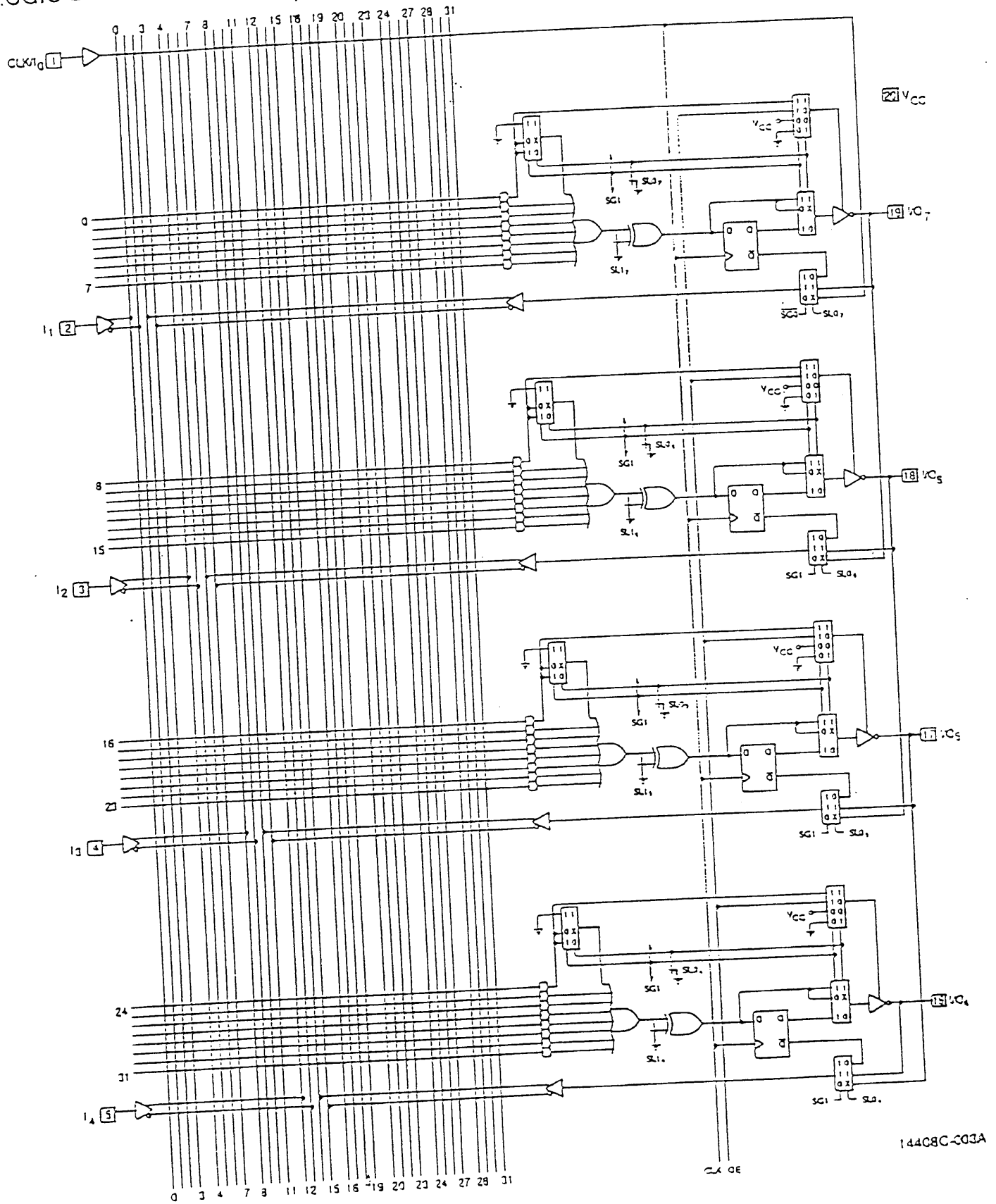

LOGIC DIAGRAM (Continued)

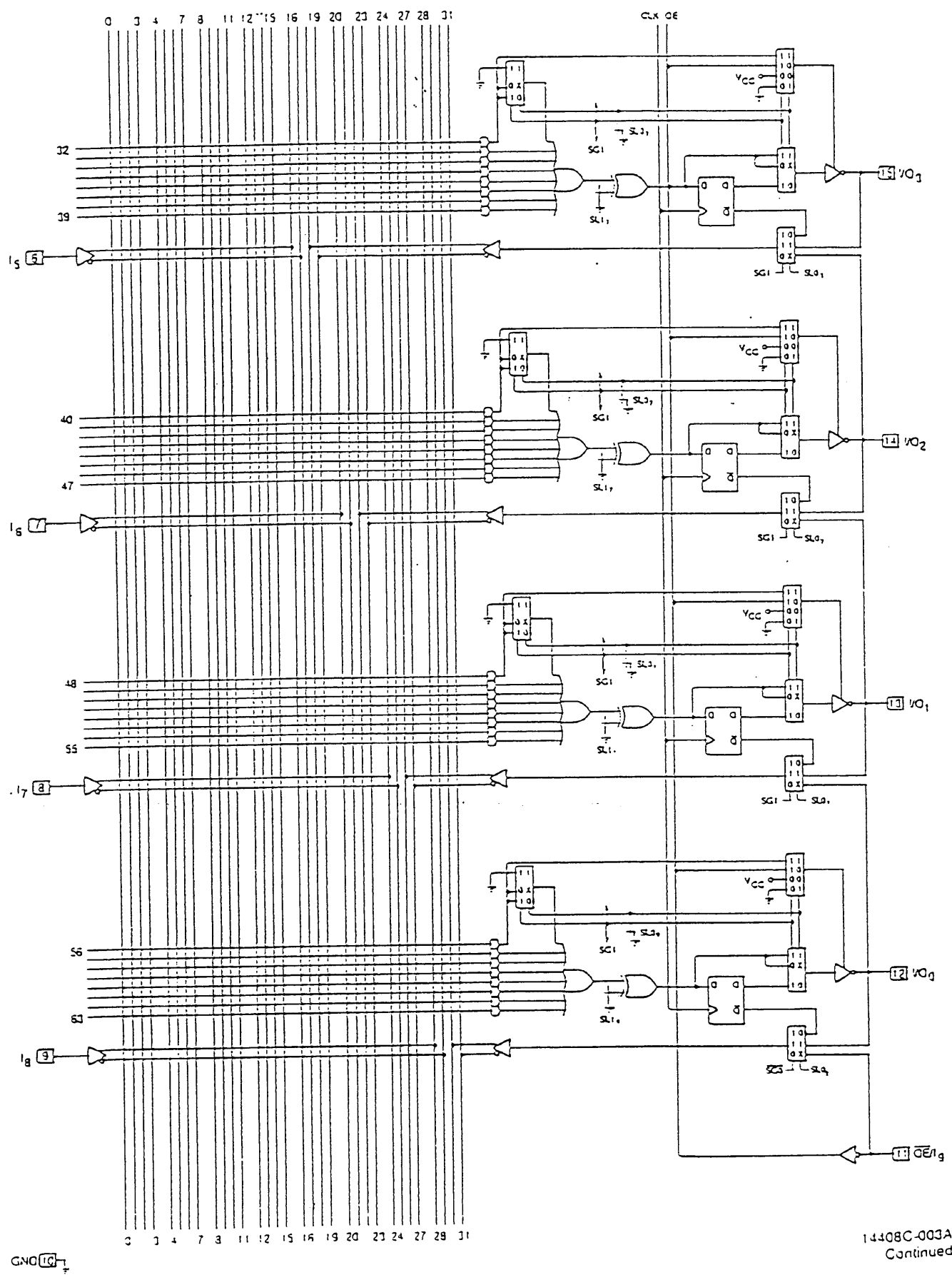

14408C-003A
Continued

ABSOLUTE MAXIMUM RATINGS

Storage Temperature	-65°C to +150°C
Ambient Temperature with Power Applied	-55°C to +125°C
Supply Voltage with Respect to Ground	-0.5 V to +7.0 V
DC Input Voltage	-0.5 V to $V_{CC} + 0.5 V$
DC Output or I/O Pin Voltage	-0.5 V to $V_{CC} + 0.5 V$
Static Discharge Voltage	2001 V
Latchup Current ($T_A = 0^\circ\text{C}$ to 75°C)	100 mA

Stresses above those listed under Absolute Maximum Ratings may cause permanent device failure. Functionality at or above these limits is not implied. Exposure to Absolute Maximum Ratings for extended periods may affect device reliability. Programming conditions may differ.

OPERATING RANGES

Commercial (C) Devices

Temperature (T_A) Operating in Free Air	0°C to +75°C
Supply Voltage (V_{CC}) with Respect to Ground	+4.75 V to +5.25 V

Operating ranges define those limits between which the functionality of the device is guaranteed.

DC CHARACTERISTICS over COMMERCIAL operating ranges unless otherwise specified

Parameter Symbol	Parameter Description	Test Conditions	Min.	Max.	Unit
V_{OH}	Output HIGH Voltage	$I_{OH} = -3.2 \text{ mA}$ $V_{IN} = V_{IH}$ or V_{IL} $V_{CC} = \text{Min.}$	2.4		V
V_{OL}	Output LOW Voltage	$I_{OL} = 24 \text{ mA}$ $V_{IN} = V_{IH}$ or V_{IL} $V_{CC} = \text{Min.}$		0.5	V
V_{IH}	Input HIGH Voltage	Guaranteed Input Logical HIGH Voltage for all Inputs (Note 1)	2.0		V
V_{IL}	Input LOW Voltage	Guaranteed Input Logical LOW Voltage for all Inputs (Note 1)		0.8	V
I_{IH}	Input HIGH Leakage Current	$V_{IN} = 5.25 \text{ V}$, $V_{CC} = \text{Max.}$ (Note 2)		10	μA
I_{IL}	Input LOW Leakage Current	$V_{IN} = 0 \text{ V}$, $V_{CC} = \text{Max.}$ (Note 2)		-100	μA
I_{OZH}	Off-State Output Leakage Current HIGH	$V_{OUT} = 5.25 \text{ V}$, $V_{CC} = \text{Max.}$ $V_{IN} = V_{IH}$ or V_{IL} (Note 2)		10	μA
I_{OLZ}	Off-State Output Leakage Current LOW	$V_{OUT} = 0 \text{ V}$, $V_{CC} = \text{Max.}$ $V_{IN} = V_{IH}$ or V_{IL} (Note 2)		-100	μA
I_{SC}	Output Short-Circuit Current	$V_{OUT} = 0.5 \text{ V}$ $V_{CC} = \text{Max.}$ (Note 3)	-30	-150	mA
I_{CC}	Supply Current (Dynamic)	Outputs Open ($I_{OUT} = 0 \text{ mA}$) $V_{CC} = \text{Max.}$, $f = 25 \text{ MHz}$		115	mA

Notes:

- These are absolute values with respect to device ground and all overshoots due to system or tester noise are included.
- V_{IO} pin leakage is the worst case of I_{IL} and I_{OLZ} (or I_{IH} and I_{OZH}).
- Not more than one output should be shorted at a time and duration of the short-circuit should not exceed one second. $V_{OUT} = 0.5 \text{ V}$ has been chosen to avoid test problems caused by tester ground degradation.

CAPACITANCE (Note 1)

Parameter Symbol	Parameter Descriptions	Test Conditions		Typ.	Unit
C_{in}	Input Capacitance	$V_{in} = 2.0\text{ V}$	$V_{cc} = 5.0\text{ V}, T_A = 25^\circ\text{C},$ $f = 1\text{ MHz}$	5	pF
C_{out}	Output Capacitance	$V_{out} = 2.0\text{ V}$		8	pF

Note:

1. These parameters are not 100% tested, but are evaluated at initial characterization and at any time the design is modified where capacitance may be affected.

SWITCHING CHARACTERISTICS over COMMERCIAL operating ranges (Note 2)

Parameter Symbol	Parameter Description		Min.	Max.	Unit
t_{po}	Input or Feedback to Combinatorial Output	8 Outputs Switching		7.5	ns
		1 Output Switching		7	ns
t_s	Setup Time from Input or Feedback to Clock		5		
t_h	Hold Time		0		ns
t_{co}	Clock to Output			5	ns
t_{wL}	Clock Width	LOW	4		ns
t_{wH}		HIGH	4		ns
f_{max}	Maximum Frequency (Note 3)	External Feedback	$1/(t_s+t_{co})$	100	MHz
		Internal Feedback (f_{cint})		125	
		No Feedback	$1/(t_{wH}+t_{wL})$	125	MHz
t_{pZx}	\overline{OE} to Output Enable			6	ns
t_{pZz}	\overline{OE} to Output Disable			6	ns
t_{EA}	Input to Output Enable Using Product Term Control			9	ns
t_{ER}	Input to Output Disable Using Product Term Control			9	ns

Notes:

2. See Switching Test Circuit for test conditions.
3. These parameters are not 100% tested, but are calculated at initial characterization and at any time the design is modified where frequency may be affected.

ABSOLUTE MAXIMUM RATINGS

Storage Temperature	-65°C to +150°C
Ambient Temperature with Power Applied	-55°C to +125°C
Supply Voltage with respect to Ground	-0.5 V to +7.0 V
CMOS Input Voltage	-0.5 V to V _{CC} + 0.5 V
CMOS Output or I/O Pin Voltage	-0.5 V to V _{CC} + 0.5 V
Static Discharge Voltage	2001 V
Latchup Current (T _A = 0°C to 75°C)	100 mA

OPERATING RANGES

Commercial (C) Devices

Temperature (T _A) Operating in Free Air	0°C to +75°C
Supply Voltage (V _{CC}) with Respect to Ground	+4.75 V to +5.25 V

Operating ranges define those limits between which the functionality of the device is guaranteed.

Stresses above those listed under Absolute Maximum Ratings may cause permanent device failure. Functionality at or above these limits is not implied. Exposure to Absolute Maximum Ratings for extended periods may affect device reliability. Programming conditions may differ.

DC CHARACTERISTICS over COMMERCIAL operating ranges unless otherwise specified

Parameter Symbol	Parameter Description	Test Conditions	Min.	Max.	Unit
V _{OH}	Output HIGH Voltage	I _{OH} = -3.2 mA V _{IN} = V _{IH} or V _{IL} V _{CC} = Min.	2.4		V
V _{OL}	Output LOW Voltage	I _{OL} = 24 mA V _{IN} = V _{IH} or V _{IL} V _{CC} = Min.		0.5	V
V _{IH}	Input HIGH Voltage	Guaranteed Input Logical HIGH Voltage for all Inputs (Note 1)	2.0		V
V _{IL}	Input LOW Voltage	Guaranteed Input Logical LOW Voltage for all Inputs (Note 1)		0.8	V
I _{IH}	Input HIGH Leakage Current	V _{IN} = 5.25 V, V _{CC} = Max. (Note 2)		10	μA
I _{IL}	Input LOW Leakage Current	V _{IN} = 0 V, V _{CC} = Max. (Note 2)		-10	μA
I _{OZH}	Off-State Output Leakage Current HIGH	V _{OUT} = 5.25 V, V _{CC} = Max. V _{IN} = V _{IH} or V _{IL} (Note 2)		10	μA
I _{OZL}	Off-State Output Leakage Current LOW	V _{OUT} = 0 V, V _{CC} = Max. V _{IN} = V _{IH} or V _{IL} (Note 2)		-10	μA
I _{sc}	Output Short-Circuit Current	V _{OUT} = 0.5 V V _{CC} = Max. (Note 3)	-30	-150	mA
I _{CC}	Supply Current (Dynamic)	Outputs Open (I _{OUT} = 0 mA) V _{CC} = Max., f = 25 MHz		115	mA

- Notes:
1. These are absolute values with respect to device ground and all overshoots due to system or tester noise are included.
 2. VO pin leakage is the worst case of I_{IL} and I_{OZL} (or I_{IH} and I_{OZH}).
 3. Not more than one output should be shorted at a time and duration of the short-circuit should not exceed one second. V_{OUT} = 0.5 V has been chosen to avoid test problems caused by tester ground degradation.

CAPACITANCE (Note 1)

Parameter Symbol	Parameter Descriptions	Test Conditions		Typ.	Unit
C_{IN}	Input Capacitance	$V_{IN} = 2.0\text{ V}$	$V_{CC} = 5.0\text{ V}, T_A = 25^\circ\text{C},$ $f = 1\text{ MHz}$	5	μF
C_{OUT}	Output Capacitance	$V_{OUT} = 2.0\text{ V}$		8	μF

Note:

1. These parameters are not 100% tested, but are evaluated at initial characterization and at any time the design is modified where capacitance may be affected.

SWITCHING CHARACTERISTICS over COMMERCIAL operating ranges (Note 2)

Parameter Symbol	Parameter Description		Min.	Max.	Unit
t_{PO}	Input or Feedback to Combinatorial Output			10	ns
t_S	Setup Time from Input or Feedback to Clock		7.5		
t_H	Hold Time		0		ns
t_{CO}	Clock to Output			7.5	ns
t_{WL}	Clock Width	LOW	6		ns
t_{WH}		HIGH	6		ns
f_{MAX}	Maximum Frequency (Note 3)	External Feedback	$1/(t_S+t_{CO})$	66.7	MHz
		Internal Feedback (f_{CNT})		71.4	MHz
		No Feedback	$1/(t_{WH}+t_{WL})$	83.3	MHz
t_{PXZ}	\overline{OE} to Output Enable			10	ns
t_{PXZ}	\overline{OE} to Output Disable			10	ns
t_{EA}	Input to Output Enable Using Product Term Control			10	ns
t_{ER}	Input to Output Disable Using Product Term Control			10	ns

Notes:

2. See Switching Test Circuit for test conditions.
3. These parameters are not 100% tested, but are calculated at initial characterization and at any time the design is modified where frequency may be affected.

ABSOLUTE MAXIMUM RATINGS

Storage Temperature	-65°C to +150°C
Ambient Temperature with Power Applied	-55°C to +125°C
Supply Voltage with Respect to Ground	-0.5 V to +7.0 V
DC Input Voltage	-0.5 V to V _{CC} + 0.5 V
DC Output or I/O Pin Voltage	-0.5 V to V _{CC} + 0.5 V
Static Discharge Voltage	2001 V
Latchup Current (T _A = 0°C to 75°C)	100 mA

OPERATING RANGES

Commercial (C) Devices

Temperature (T _A) Operating in Free Air	0°C to +75°C
Supply Voltage (V _{CC}) with Respect to Ground	+4.75 V to +5.25 V

Operating ranges define those limits between which the functionality of the device is guaranteed.

Stresses above those listed under Absolute Maximum Ratings may cause permanent device failure. Functionality at or above these limits is not implied. Exposure to Absolute Maximum Ratings for extended periods may affect device reliability. Programming conditions may differ.

DC CHARACTERISTICS over COMMERCIAL operating ranges unless otherwise specified

Parameter Symbol	Parameter Description	Test Conditions	Min.	Max.	Unit
V _{OH}	Output HIGH Voltage	I _{OH} = -3.2 mA V _{IN} = V _{IH} or V _{IL} V _{CC} = Min.	2.4		V
V _{OL}	Output LOW Voltage	I _{OL} = 24 mA V _{IN} = V _{IH} or V _{IL} V _{CC} = Min.		0.5	V
V _{IH}	Input HIGH Voltage	Guaranteed Input Logical HIGH Voltage for all Inputs (Note 1)	2.0		V
V _{IL}	Input LOW Voltage	Guaranteed Input Logical LOW Voltage for all Inputs (Note 1)		0.8	V
I _{IH}	Input HIGH Leakage Current	V _{IN} = 5.25 V, V _{CC} = Max. (Note 2)		10	μA
I _{IL}	Input LOW Leakage Current	V _{IN} = 0 V, V _{CC} = Max. (Note 2)		-10	μA
I _{OZH}	Off-State Output Leakage Current HIGH	V _{OUT} = 5.25 V, V _{CC} = Max. V _{IN} = V _{IH} or V _{IL} (Note 2)		10	μA
I _{OZL}	Off-State Output Leakage Current LOW	V _{OUT} = 0 V, V _{CC} = Max. V _{IN} = V _{IH} or V _{IL} (Note 2)		-10	μA
I _{SC}	Output Short-Circuit Current	V _{OUT} = 0.5 V V _{CC} = Max. (Note 3)	-30	-150	mA
I _{CC}	Supply Current (Dynamic)	Outputs Open (I _{OUT} = 0 mA)	H	90	mA
		V _{CC} = Max., f = 25 MHz	Q	55	

Notes:

1. These are absolute values with respect to device ground and all overshoots due to system or tester noise are included.
2. I/O pin leakage is the worst case of I_{IL} and I_{OZL} (or I_{IH} and I_{OZH}).
3. Not more than one output should be shorted at a time and duration of the short-circuit should not exceed one second. V_{OUT} = 0.5 V has been chosen to avoid test problems caused by tester ground degradation.

CAPACITANCE (Note 1)

Parameter Symbol	Parameter Descriptions	Test Conditions		Typ.	Unit
C _{IN}	Input Capacitance	V _{IN} = 2.0 V	V _{CC} = 5.0 V, T _A = 25°C, f = 1 MHz	5	pF
C _{OUT}	Output Capacitance	V _{OUT} = 2.0 V		8	pF

Note:

1. These parameters are not 100% tested, but are evaluated at initial characterization and at any time the design is modified where capacitance may be affected.

SWITCHING CHARACTERISTICS over COMMERCIAL operating ranges (Note 2)

Parameter Symbol	Parameter Description	-15		-25		Unit
		Min.	Max.	Min.	Max.	
t _{PO}	Input or Feedback to Combinatorial Output		15		25	ns
t _S	Setup Time from Input or Feedback to Clock	12		15		
t _H	Hold Time	0		0		ns
t _{CO}	Clock to Output		10		12	ns
t _{WL}	Clock Width	LOW	8	12		ns
t _{WH}		HIGH	8	12		ns
f _{MAX}	Maximum Frequency (Note 3)	External Feedback	1/(t _S +t _{CO})	45.5	37	MHz
		Internal Feedback (f _{CNT})		50	40	MHz
		No Feedback	1/(t _{WH} +t _{WL})	62.5	41.6	MHz
t _{PZX}	\overline{OE} to Output Enable		15		20	ns
t _{PXZ}	\overline{OE} to Output Disable		15		20	ns
t _{EA}	Input to Output Enable Using Product Term Control		15		20	ns
t _{ER}	Input to Output Disable Using Product Term Control		15		20	ns

Notes:

2. See Switching Test Circuit for test conditions.
3. These parameters are not 100% tested, but are calculated at initial characterization and at any time the design is modified where frequency may be affected.

ABSOLUTE MAXIMUM RATINGS

Storage Temperature	-65°C to +150°C
Ambient Temperature with Power Applied	-55°C to +125°C
Supply Voltage with Respect to Ground	-0.5 V to +7.0 V
DC Input Voltage	-0.5 V to Vcc + 1.0 V
DC Output or I/O Pin Voltage	-0.5 V to Vcc + 1.0 V
Static Discharge Voltage	2001 V
Latchup Current (Tc = -55°C to +125°C)	100 mA

Stresses above those listed under Absolute Maximum Ratings may cause permanent device failure. Functionality at or above these limits is not implied. Exposure to Absolute Maximum Ratings for extended periods may affect device reliability. Programming conditions may differ. Absolute Maximum Ratings are for system design reference; parameters given are not tested.

OPERATING RANGES

Military (M) Devices (Note 1)	
Operating Case Temperature (Tc)	-55°C to +125°C
Supply Voltage (Vcc) with Respect to Ground	+4.5 V to +5.5 V

Operating ranges define those limits between which the functionality of the device is guaranteed.

Note:

- Military products are tested at Tc = +25°C, +125°C and -55°C, per MIL-STD-883.

DC CHARACTERISTICS over MILITARY operating ranges unless otherwise specified (Note 2)

PRELIMINARY					
Parameter Symbol	Parameter Description	Test Conditions	Min.	Max.	Unit
V _{OH}	Output HIGH Voltage	I _{OH} = -2.0 mA V _{IN} = V _{IH} or V _{IL} V _{CC} = Min.	2.4		V
V _{OL}	Output LOW Voltage	I _{OL} = 12 mA V _{IN} = V _{IH} or V _{IL} V _{CC} = Min.		0.5	V
V _{IH}	Input HIGH Voltage	Guaranteed Input Logical HIGH Voltage for all Inputs (Note 3)	2.0		V
V _{IL}	Input LOW Voltage	Guaranteed Input Logical LOW Voltage for all Inputs (Note 3)		0.8	V
I _{IH}	Input HIGH Leakage Current	V _{IN} = 5.5 V, V _{CC} = Max. (Note 4)		10	μA
I _{IL}	Input LOW Leakage Current	V _{IN} = 0 V, V _{CC} = Max. (Note 4)		-100	μA
I _{OZH}	Off-State Output Leakage Current HIGH	V _{OUT} = 5.5 V, V _{CC} = Max. V _{IN} = V _{IH} or V _{IL} (Note 4)		10	μA
I _{OZL}	Off-State Output Leakage Current LOW	V _{OUT} = 0 V, V _{CC} = Max. V _{IN} = V _{IH} or V _{IL} (Note 4)		-100	μA
I _{SC}	Output Short-Circuit Current	V _{CC} = 5.0 V, V _{OUT} = 0.5 V (Note 5), T = 25°C	-30	-150	mA
I _{CC}	Supply Current (Dynamic)	Outputs Open (I _{OUT} = 0 mA) V _{CC} = Max., f = 25 MHz		130	mA

Notes:

- For APL products, Group A, Subgroups 1, 2 and 3 are tested per MIL-STD-883, Method 5005, unless otherwise noted.
- V_{IL} and V_{IH} are input conditions of output tests and are not themselves directly tested. V_{IL} and V_{IH} are absolute voltages with respect to device ground and include all overshoots due to system and/or tester noise. Do not attempt to test these values without suitable equipment.
- I/O pin leakage is the worst case of I_{IL} and I_{OZL} (or I_{IH} and I_{OZH}).
- Not more than one output should be shorted at a time and duration of the short-circuit should not exceed one second. V_{OUT} = 0.5 V has been chosen to avoid test problems caused by tester ground degradation. This parameter is not 100% tested, but is evaluated at initial characterization and at any time the design is modified where I_{SC} may be affected.

CAPACITANCE (Note 1)

Parameter Symbol	Parameter Descriptions	Test Conditions		Typ.	Unit
C_{IN}	Input Capacitance	$V_{IN} = 2.0\text{ V}$	$V_{CC} = 5.0\text{ V}, T_A = 25^\circ\text{C},$	8	pF
C_{OUT}	Output Capacitance	$V_{OUT} = 2.0\text{ V}$	$f = 1\text{ MHz}$	8	pF

Note:

- These parameters are not 100% tested, but are evaluated at initial characterization and at any time the design is modified where capacitance may be affected.

SWITCHING CHARACTERISTICS over MILITARY operating ranges (Note 2)

PRELIMINARY					
Parameter Symbol	Parameter Description		Min.	Max.	Unit
t_{PD}	Input or Feedback to Combinatorial Output			10	ns
t_s	Setup Time from Input or Feedback to Clock		10		ns
t_H	Hold Time		0		ns
t_{CO}	Clock to Output			7	ns
t_{WL}	Clock Width	LOW	8		ns
t_{WH}		HIGH	8		ns
f_{MAX}	Maximum Frequency (Note 3)	External Feedback	$1/(t_s+t_{CO})$	58.5	MHz
		Internal Feedback (f_{CNT})		62.5	MHz
		No Feedback	$1/(t_{WH}+t_{WL})$	62.5	MHz
t_{PZX}	\overline{OE} to Output Enable (Note 3)			10	ns
t_{PXZ}	\overline{OE} to Output Disable (Note 3)			10	ns
t_{EA}	Input to Output Enable Using Product Term Control (Note 3)			10	ns
t_{ED}	Input to Output Disable Using Product Term Control (Note 3)			10	ns

Notes:

- See Switching Test Circuit for test conditions. For APL Products, Group A, Subgroups 9, 10, and 11 are tested per MIL-STD-883, Method 5005, unless otherwise noted.
- These parameters are not 100% tested, but are evaluated at initial characterization and at any time the design is modified where these parameters may be affected.

ABSOLUTE MAXIMUM RATINGS

Storage Temperature	-65°C to +150°C
Ambient Temperature with Power Applied	-55°C to +125°C
Supply Voltage with Respect to Ground	-0.5 V to +7.0 V
DC Input Voltage	-0.5 V to Vcc + 1.0 V
DC Output or I/O Pin Voltage	-0.5 V to Vcc + 1.0 V
Static Discharge Voltage	2001 V
Latchup Current (Tc = -55°C to +125°C)	100 mA

Stresses above those listed under Absolute Maximum Ratings may cause permanent device failure. Functionality at or above these limits is not implied. Exposure to Absolute Maximum Ratings for extended periods may affect device reliability. Programming conditions may differ. Absolute Maximum Ratings are for system design reference; parameters given are not tested.

OPERATING RANGES

Military (M) Devices (Note 1)	
Operating Case Temperature (Tc)	-55°C to +125°C
Supply Voltage (Vcc) with Respect to Ground	+4.5 V to +5.5 V

Operating ranges define those limits between which the functionality of the device is guaranteed.

Note:

- Military products are tested at Tc = +25°C, +125°C and -55°C, per MIL-STD-883.

DC CHARACTERISTICS over MILITARY operating ranges unless otherwise specified (Note 2)

Parameter Symbol	Parameter Description	Test Conditions	Min.	Max.	Unit
V _{OH}	Output HIGH Voltage	I _{OH} = -2.0 mA V _{IN} = V _{IH} or V _{IL} V _{CC} = Min.	2.4		V
V _{OL}	Output LOW Voltage	I _{OL} = 12 mA V _{IN} = V _{IH} or V _{IL} V _{CC} = Min.		0.5	V
V _{IH}	Input HIGH Voltage	Guaranteed Input Logical HIGH Voltage for all Inputs (Note 3)	2.0		V
V _{IL}	Input LOW Voltage	Guaranteed Input Logical LOW Voltage for all Inputs (Note 3)		0.8	V
I _{IH}	Input HIGH Leakage Current	V _{IN} = 5.5 V, V _{CC} = Max. (Note 4)		10	μA
I _{IL}	Input LOW Leakage Current	V _{IN} = 0 V, V _{CC} = Max. (Note 4)		-10	μA
I _{OZH}	Off-State Output Leakage Current HIGH	V _{OUT} = 5.5 V, V _{CC} = Max. V _{IN} = V _{IH} or V _{IL} (Note 4)		10	μA
I _{OZL}	Off-State Output Leakage Current LOW	V _{OUT} = 0 V, V _{CC} = Max. V _{IN} = V _{IH} or V _{IL} (Note 4)		-100	μA
I _{SC}	Output Short-Circuit Current	V _{CC} = 5.0 V, V _{OUT} = 0.5 V (Note 5), T = 25°C	-30	-150	mA
I _{CC}	Supply Current (Dynamic)	Outputs Open (I _{OUT} = 0 mA) V _{CC} = Max., f = 25 MHz		130	mA

Notes:

- For APL products, Group A, Subgroups 1, 2 and 3 are tested per MIL-STD-883, Method 5005, unless otherwise noted.
- V_{IL} and V_{IH} are input conditions of output tests and are not themselves directly tested. V_{IL} and V_{IH} are absolute voltages with respect to device ground and include all overshoots due to system and/or tester noise. Do not attempt to test these values without suitable equipment.
- I/O pin leakage is the worst case of I_{IL} and I_{OZL} (or I_{IH} and I_{OZH}).
- Not more than one output should be shorted at a time and duration of the short-circuit should not exceed one second. V_{OUT} = 0.5 V has been chosen to avoid test problems caused by tester ground degradation. This parameter is not 100% tested, but is evaluated at initial characterization and at any time the design is modified where I_{SC} may be affected.

CAPACITANCE (Note 1)

Parameter Symbol	Parameter Descriptions	Test Conditions		Typ.	Unit
C_{IN}	Input Capacitance	$V_{IN} = 2.0 V$	$V_{CC} = 5.0 V, T_A = 25^\circ C,$ $f = 1 MHz$	8	pF
C_{OUT}	Output Capacitance	$V_{OUT} = 2.0 V$		8	pF

Note:

1. These parameters are not 100% tested, but are evaluated at initial characterization and at any time the design is modified where capacitance may be affected.

SWITCHING CHARACTERISTICS over MILITARY operating ranges (Note 2)

Parameter Symbol	Parameter Description		Min.	Max.	Unit
t_{PD}	Input or Feedback to Combinatorial Output			15	ns
t_s	Setup Time from Input or Feedback to Clock		12		ns
t_H	Hold Time		0		ns
t_{CO}	Clock to Output			12	ns
t_{WL}	Clock Width	LOW	10		ns
t_{WH}		HIGH	10		ns
f_{MAX}	Maximum Frequency (Note 3)	External Feedback	$1/(t_s + t_{CO})$	41.6	MHz
		Internal Feedback (f_{CNT})		45.5	MHz
		No Feedback	$1/(t_{WH} + t_{WL})$	50	MHz
t_{PZx}	\overline{OE} to Output Enable (Note 3)			15	ns
t_{PXZ}	\overline{OE} to Output Disable (Note 3)			15	ns
t_{EA}	Input to Output Enable Using Product Term Control (Note 3)			15	ns
t_{ER}	Input to Output Disable Using Product Term Control (Note 3)			15	ns

Notes:

2. See Switching Test Circuit for test conditions. For APL Products, Group A, Subgroups 9, 10, and 11 are tested per MIL-STD-883, Method 5005, unless otherwise noted.
3. These parameters are not 100% tested, but are evaluated at initial characterization and at any time the design is modified where these parameters may be affected.

ABSOLUTE MAXIMUM RATINGS

Storage Temperature	-65°C to +150°C
Ambient Temperature with Power Applied	-55°C to +125°C
Supply Voltage with Respect to Ground	-0.5 V to +7.0 V
DC Input Voltage	-0.5 V to $V_{CC} + 1.0$ V
DC Output or I/O Pin Voltage	-0.5 V to $V_{CC} + 1.0$ V
Static Discharge Voltage	2001 V
Latchup Current ($T_c = -55^\circ\text{C}$ to $+125^\circ\text{C}$)	100 mA

Stresses above those listed under Absolute Maximum Ratings may cause permanent device failure. Functionality at or above these limits is not implied. Exposure to Absolute Maximum Ratings for extended periods may affect device reliability. Programming conditions may differ. Absolute Maximum Ratings are for system design reference; parameters given are not tested.

OPERATING RANGES

Military (M)-Devices (Note 1)	
Operating Case Temperature (T_c)	-55°C to +125°C
Supply Voltage (V_{CC}) with Respect to Ground	+4.5 V to +5.5 V

Operating ranges define those limits between which the functionality of the device is guaranteed.

Note:

- Military products are tested at $T_c = +25^\circ\text{C}$, $+125^\circ\text{C}$ and -55°C , per MIL-STD-883.

DC CHARACTERISTICS over MILITARY operating ranges unless otherwise specified (Note 2)

Parameter Symbol	Parameter Description	Test Conditions	Min.	Max.	Unit
V_{OH}	Output HIGH Voltage	$I_{OH} = -2.0$ mA $V_{IN} = V_{IH}$ or V_{IL} $V_{CC} = \text{Min.}$	2.4		V
V_{OL}	Output LOW Voltage	$I_{OL} = 12$ mA $V_{IN} = V_{IH}$ or V_{IL} $V_{CC} = \text{Min.}$		0.5	V
V_{IH}	Input HIGH Voltage	Guaranteed Input Logical HIGH Voltage for all Inputs (Note 3)	2.0		V
V_{IL}	Input LOW Voltage	Guaranteed Input Logical LOW Voltage for all Inputs (Note 3)		0.8	V
I_{IH}	Input HIGH Leakage Current	$V_{IN} = 5.5$ V, $V_{CC} = \text{Max.}$ (Note 4)		10	μA
I_{IL}	Input LOW Leakage Current	$V_{IN} = 0$ V, $V_{CC} = \text{Max.}$ (Note 4)		-10	μA
I_{OZH}	Off-State Output Leakage Current HIGH	$V_{OUT} = 5.5$ V, $V_{CC} = \text{Max.}$ $V_{IN} = V_{IH}$ or V_{IL} (Note 4)		10	μA
I_{OZL}	Off-State Output Leakage Current LOW	$V_{OUT} = 0$ V, $V_{CC} = \text{Max.}$ $V_{IN} = V_{IH}$ or V_{IL} (Note 4)		-100	μA
I_{SC}	Output Short-Circuit Current	$V_{CC} = 5.0$ V, $V_{OUT} = 0.5$ V (Note 5), $T = 25^\circ\text{C}$	-30	-150	mA
I_{CC}	Supply Current (Dynamic)	Outputs Open ($I_{OUT} = 0$ mA) $V_{CC} = \text{Max.}$, $f = 25$ MHz		130	mA

Notes:

- For APL products, Group A, Subgroups 1, 2 and 3 are tested per MIL-STD-883, Method 5005, unless otherwise noted.
- V_{IL} and V_{IH} are input conditions of output tests and are not themselves directly tested. V_{IL} and V_{IH} are absolute voltages with respect to device ground and include all overshoots due to system and/or tester noise. Do not attempt to test these values without suitable equipment.
- I/O pin leakage is the worst case of I_{IL} and I_{OZL} (or I_{IH} and I_{OZH}).
- Not more than one output should be shorted at a time and duration of the short-circuit should not exceed one second.
- $V_{OUT} = 0.5$ V has been chosen to avoid test problems caused by tester ground degradation. This parameter is not 100% tested, but is evaluated at initial characterization and at any time the design is modified where I_{SC} may be affected.

CAPACITANCE (Note 1)

Parameter Symbol	Parameter Descriptions	Test Conditions		Typ.	Unit
C_{IN}	Input Capacitance	$V_{IN} = 2.0\text{ V}$	$V_{CC} = 5.0\text{ V}, T_A = 25^\circ\text{C},$ $f = 1\text{ MHz}$	8	pF
C_{OUT}	Output Capacitance	$V_{OUT} = 2.0\text{ V}$		8	pF

- Note:
1. These parameters are not 100% tested, but are evaluated at initial characterization and at any time the design is modified where capacitance may be affected.

SWITCHING CHARACTERISTICS over MILITARY operating ranges (Note 2)

Parameter Symbol	Parameter Description	-20		-25		Unit
		Min.	Max.	Min.	Max.	
t_{PO}	Input or Feedback to Combinatorial Output		20		25	ns
t_S	Setup Time from Input or Feedback to Clock	15		15		
t_H	Hold Time	0		0		ns
t_{CO}	Clock to Output		15		20	ns
t_{WL}	Clock Width	LOW	12	15		ns
t_{WH}		HIGH	12	15		ns
f_{MAX}	Maximum Frequency (Note 3)	External Feedback $1/(t_S+t_{CO})$	33.3	28.6		MHz
		Internal Feedback (f_{CNT})	35.7	30.3		MHz
		No Feedback $1/(t_{WH}+t_{WL})$	41.7	33.3		MHz
t_{PXZ}	\overline{OE} to Output Enable (Note 3)		20		20	ns
t_{PZ}	\overline{OE} to Output Disable (Note 3)		20		20	ns
t_{EA}	Input to Output Enable Using Product Term Control (Note 3)		20		25	ns
t_{ER}	Input to Output Disable Using Product Term Control (Note 3)		20		55	ns

Notes:

2. See Switching Test Circuit for test conditions. For APL Products, Group A, Subgroups 9, 10, and 11 are tested per MIL-STD-883, Method 5005, unless otherwise noted.
3. These parameters are not 100% tested, but are evaluated at initial characterization and at any time the design is modified where these parameters may be affected.

SWITCHING WAVEFORMS

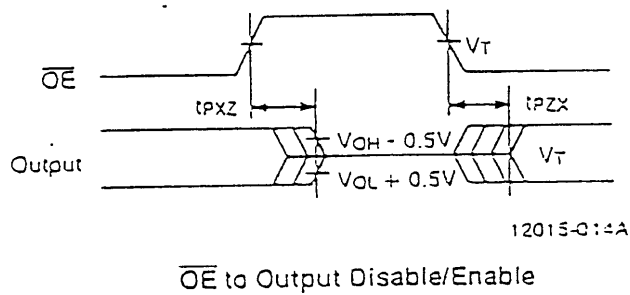
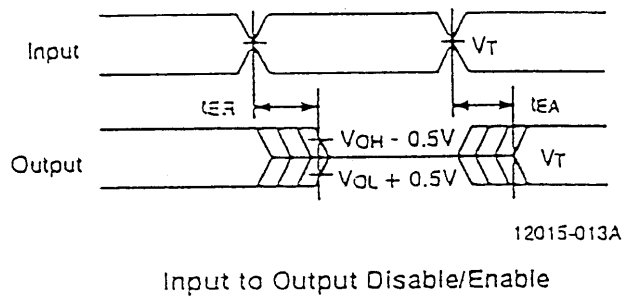
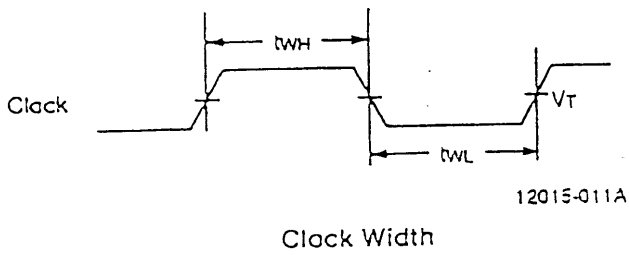
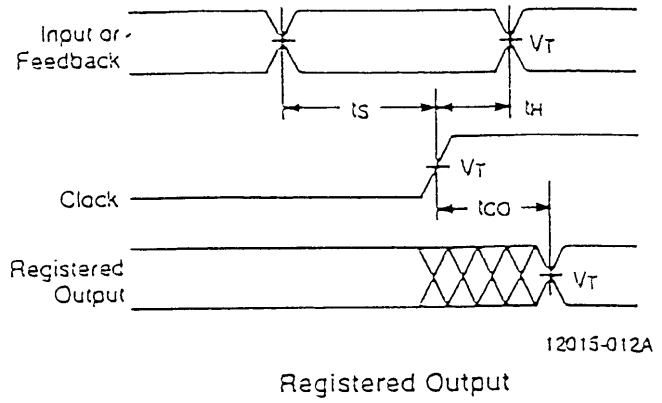
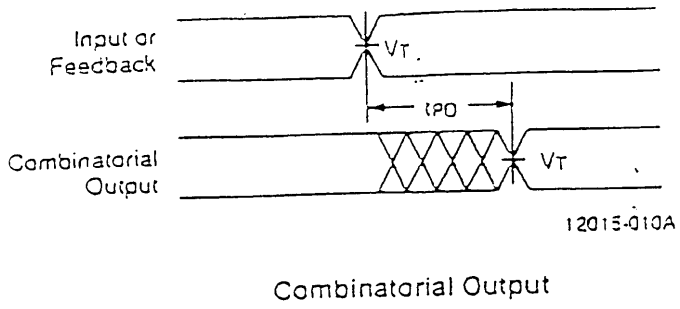

Notes:

1. $V_T = 1.5V$
2. Input pulse amplitude 0V to 3.0V.
3. Input rise and fall times 2-5 ns typical.

KEY TO SWITCHING WAVEFORMS

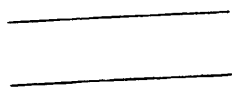
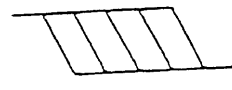
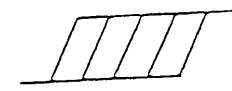
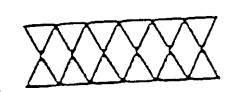
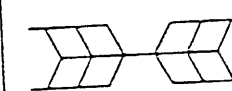
WAVEFORM	INPUTS	OUTPUTS
	Must be Steady	Will be Steady
	May Change from H to L	Will be Changing from H to L
	May Change from L to H	Will be Changing from L to H
	Don't Care, Any Change Permitted	Changing, State Unknown
	Does Not Apply	Center Line is High-Impedance "Off" State

KS00010-PAL

SWITCHING TEST CIRCUIT

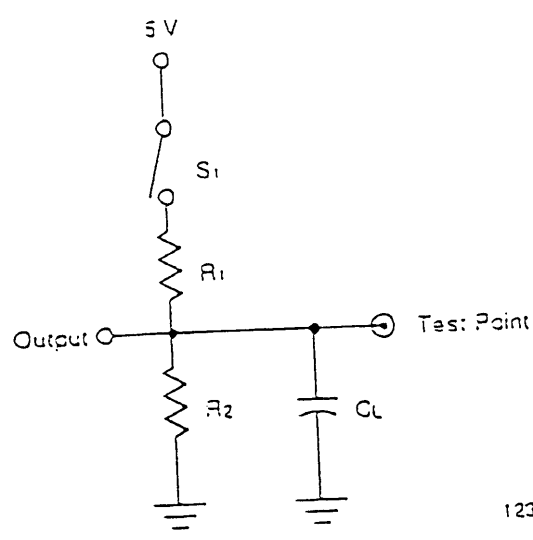

12350-019A

Specification	S ₁	C _L	Commercial		Military		Measured Output Value
			R ₁	R ₂	R ₁	R ₂	
t _{PO} , t _{CO}	Closed	50 pF	200 Ω	390 Ω	390 Ω	750 Ω	1.5 V
t _{PZX} , t _{EA}	Z → H: Open Z → L: Closed						1.5 V
t _{PXZ} , t _{ER}	H → Z: Open L → Z: Closed	5 pF					H → Z: V _{OH} - 0.5 V L → Z: V _{OL} + 0.5 V

DURANCE CHARACTERISTICS

PALCE16V8 is manufactured using AMD's advanced Electrically Erasable process. This technology uses an EE cell to replace the fuse link used in bipolar

parts. As a result, the device can be erased and reprogrammed - a feature which allows 100% testing at the factory.

durance Characteristics

Symbol	Parameter	Min.	Units	Test Conditions
OR	Min. Pattern Data Retention Time	10	Years	Max. Storage Temperature
		20	Years	Max. Operating Temperature (Military)
N	Min. Reprogramming Cycles	100	Cycles	Normal Programming Conditions

INPUT/OUTPUT EQUIVALENT SCHEMATICS

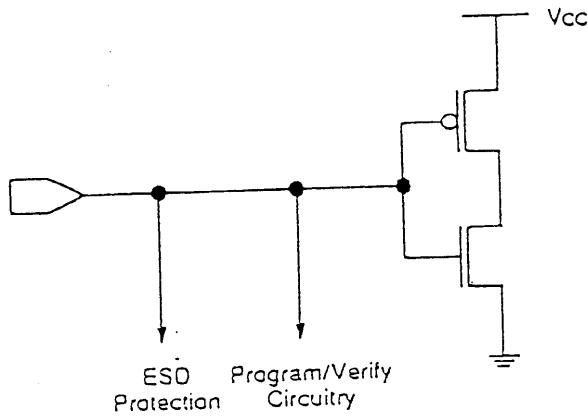

Typical Input

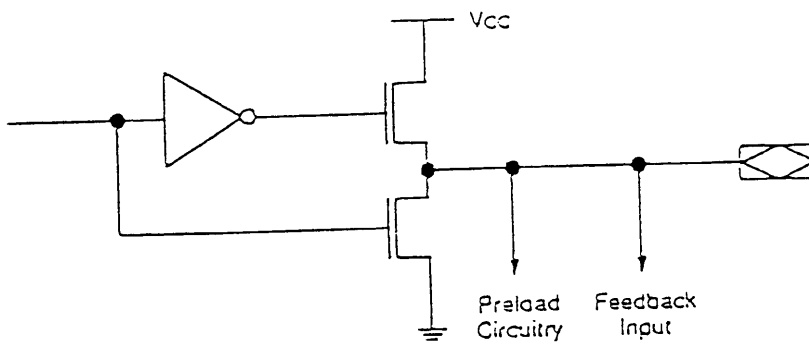

Typical Output

12197-013A

ROBUSTNESS FEATURES FOR /5 VERSIONS

The PALCE16V8H-7/5 has some unique features that make it extremely robust, especially when operating in high-speed design environments. Pull-up resistors on inputs and I/O pins cause unconnected pins to default to a known state. Input clamping circuitry limits negative

overshoot, eliminating the possibility of false clocking caused by subsequent ringing. A special noise filter makes the programming circuitry completely insensitive to any positive overshoot that has a pulse width of less than about 100 ns.

INPUT/OUTPUT EQUIVALENT SCHEMATICS FOR /5 VERSION

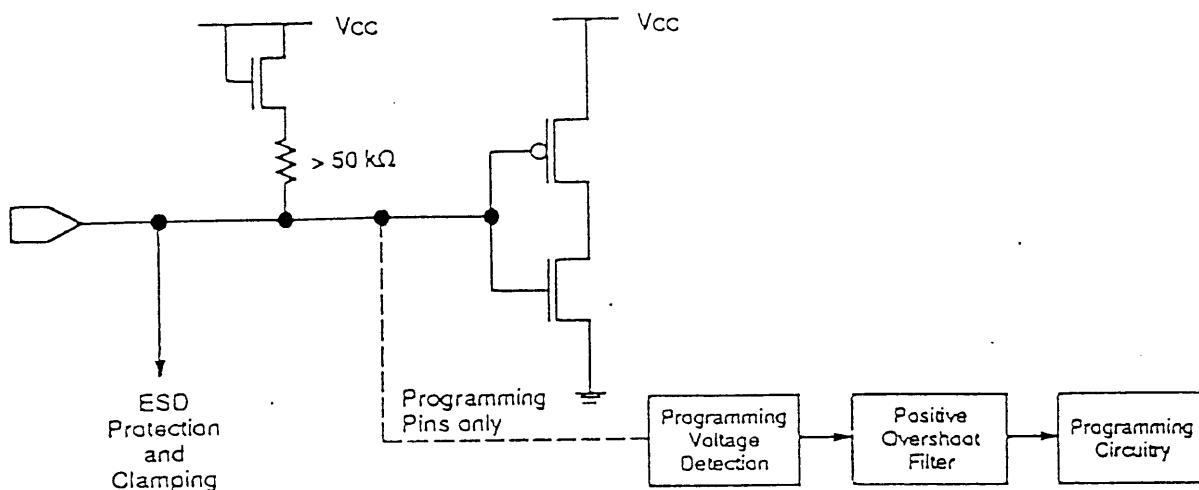

Typical Input

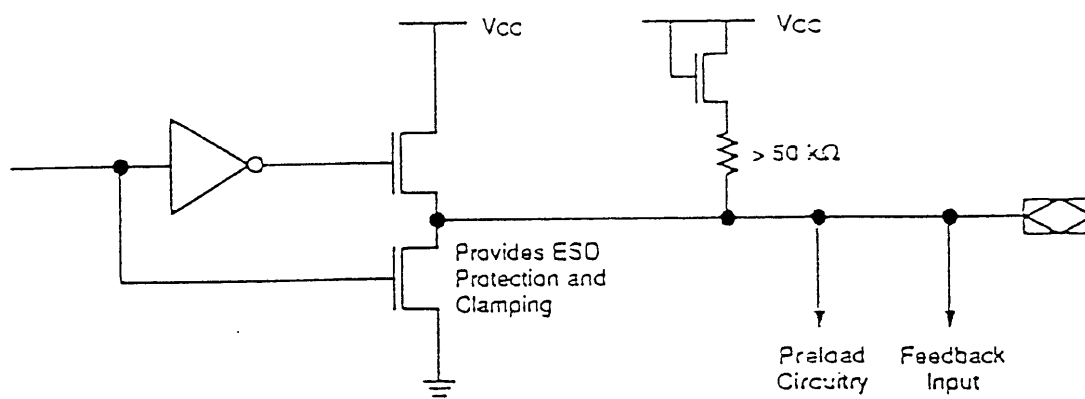

Typical Output

15407A-0018

POWER-UP RESET

The PALCE16V8 has been designed with the capability to reset during system power-up. Following power-up, flip-flops will be reset to LOW. The output state will be HIGH independent of the logic polarity. This feature provides extra flexibility to the designer and is especially valuable in simplifying state machine initialization. A timing diagram and parameter table are shown below. Due to the synchronous operation of the power-up reset

and the wide range of ways V_{CC} can rise to its steady state, two conditions are required to insure a valid power-up reset. These conditions are:

1. The V_{CC} rise must be monotonic.
2. Following reset, the clock input must not be driven from LOW to HIGH until all applicable input and feedback setup times are met.

Parameter Symbol	Parameter Descriptions	Min.	Max.	Unit
t_{PR}	Power-Up Reset Time		1000	ns
t_s	Input or Feedback Setup Time	See Switching Characteristics		
t_{WL}	Clock Width LOW			

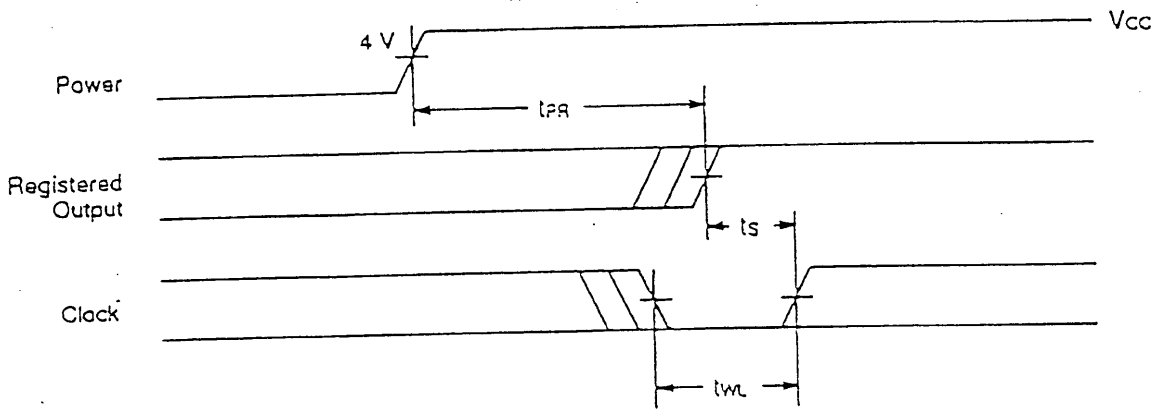

12350-324A

Power-Up Reset Waveform