

AUTOMATIC HAND DRYER

GSQ150

- *Featured with digit circuit, infrared sensor, and good interference resistant capacity.
- *High speed motor, drying hand quickly, low noise, energy saving.
- *Plastic casing design accords with structure of II class appliance, safe and elegant.
- *New design, Ornamental, exquisite.

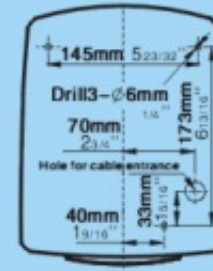
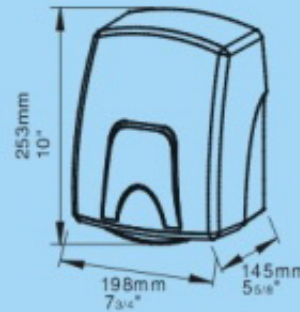

Installation templet

SPECIFICATIONS:

| | | |
|--------------------------|--------------------------|-----------------------------|
| Voltage: | 220V~/50Hz | 110-120V/60Hz |
| Rated Power: | 1500W | 1500W |
| Current: | 6.8A | 14A |
| Water splash proof: | IP22 | IP22 |
| Electric-shock safeguard | <input type="checkbox"/> | <input type="checkbox"/> |
| Blowing volume: | 88m ³ /h | 88m ³ /h |
| Air speed: | 14.5m/S | 14.5m/S |
| Dimensions: | 706x292x366mm | 27 7/8" x 14 1/2" x 14 3/8" |
| Unit weight: | 1.7kg | 3.7 lb |
| Package: (6pcs) | 12.5kg | 27.5lb |