



HDW3 Air Circuit Breaker

Reliable made affordable



About Himel



Himel is a multinational manufacturer and provider of electrical products that successfully combines global expertise with local knowledge. We focus on long-term partnership with customers and offer products that meet real needs and ensure adequate compatibility for common usage.

Our global footprint and technology allows to provide the best combination of affordable and reliable offers for low voltage power distribution, industrial automation and home electric in over 50 countries where we are present.

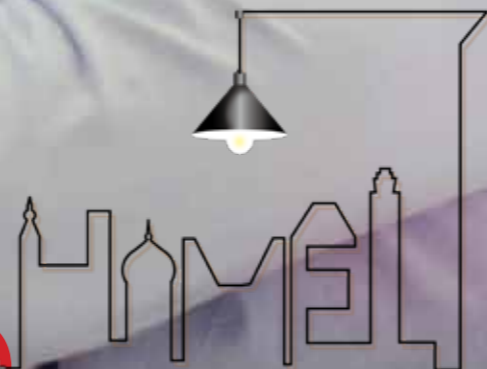

Reliable made affordable.

General contents

■ Himel HDW3 Air Circuit Breaker

- Selection guide 7
- Overview 8
- iRT 326 controller 14
- Accessory and Overview 19
- Accessory selection guide 23
- Installation Dimension..... 27
- Electrical schematic diagram 45
- Tripping curve 47
- ATS Controller 48

HDW3 A new line of Air Circuit Breaker



Himel Offer Family

We bring efficient power to every home

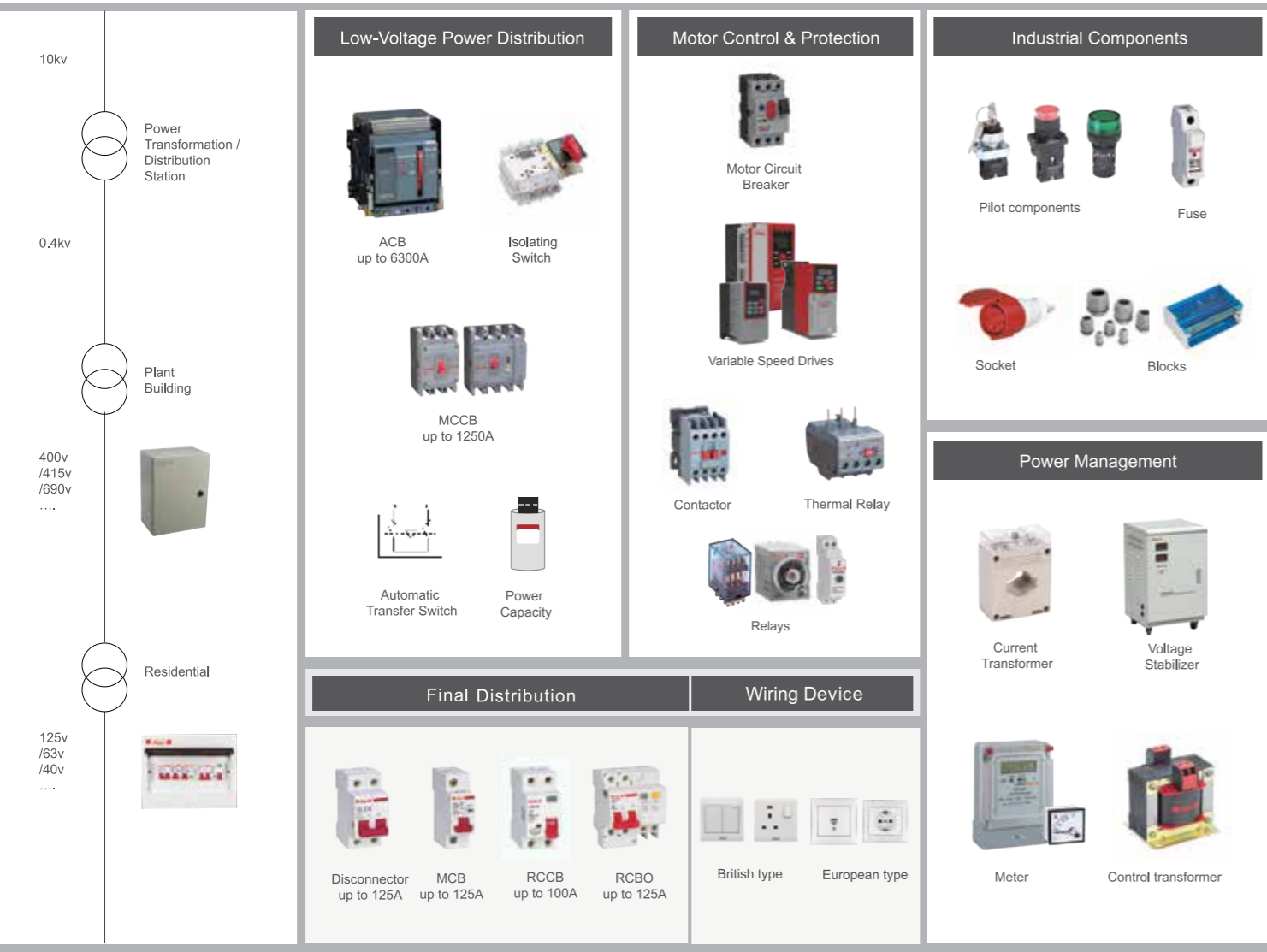

Arcing contact design ,
Enhanced **Electrical Life**



Integrated ASIC design ,
Strengthened **Stability**



Zero arcing design,
Ensured **Safety**



Fast & Flexible wiring,
Achieved **High Efficiency**



Environment , broadened **applicability**



Selection Guide



Range Presentation

HDW3 is Himel 3 series comprehensive range of Air Circuit Breakers designed to distribute electric energy and protect overload, under voltage, short circuit and ground faults

HDW3 can be mainly used in power stations, factories, mines and modern high-rise buildings with smart power distribution system.

Application standard: IEC/EN 60947-2

Features

- ◆ 6 frame size: 1000,1600,2000,3200,4000,6300AF
- ◆ Rated current In (A): 400 - 6300
- ◆ Rated voltage AC Ue (V): 400/415, 660/690
- ◆ Poles: 3 & 4
- ◆ 3 type of intelligent controllers

Online Content



HDW3

Selection code

Range name	Frame size	Breaking capacity	Rated current	Poles	Installation type
HDW3	16	M	16	3	FH
HDW3	10: 1000 16: 1600 20: 2000 32: 3200 40: 4000 63: 6300	M: Icu≠Ics≠Icw S: Icu=Ics=Icw	04: 400A 06: 630A 08: 800A 10: 1000A 12: 1250A 16: 1600A 20: 2000A 25: 2500A 32: 3200A 40: 4000A 50: 5000A 63: 6300A(only 3P)	3: 3P 4: 4P	DH: Draw-out horizontal FH: Fixed horizontal
5	5	5	4	M	
D: DC220V N: AC230V V: AC400V 5: Without MCH+XF	D: DC220V N: AC230V V: AC400V 5: Without shunt release	N: AC230V V: AC400V P: with undervoltage delayed AC230V T: with undervoltage delayed AC400V 5: Without undervoltage release	4: 4NO+4NC (1000,1600,4000AF) 6: 6NO+4NC (2000,3200,6300AF)	L: iTR326(50Hz) M: iTR326A(50Hz) H: iTR326H((50/60Hz) E: iTR326(60Hz) T: iTR326A(60Hz)	

Example: HDW316M163FH5554M: HDW3-1600M 1600A 3P Fixed breaker, M type controller, without accessory.

Note: 1000AF/1600AF the accessory is same parts.

Overview



Main Parameters

- Frame size: 1000,1600,2000,3200,4000,6300AF
- Rated current In (A): 400 ~ 6300
- Rated voltage AC Ue (V): 400/415, 660/690
- Poles: 3 & 4
- Installation method: Fixed type and draw-out type
- Wiring method: Horizontal rear connection, Vertical rear connection

Intelligent Controllers

iTR326 (basic type)
Basic protection (L, S, I & G)

iTR326A (standard type)
Basic protection
Basic measurement
Auxiliary function

iTR326H (advanced type)
Basic + high level protection
Multiple measurement
Auxiliary function
Advanced function
Communication

Accessories

- Motor operating mechanism: shunt coil, undervoltage coil, closing coil
- Intelligent controller accessories: N phase External transformer, Ground transformer, leakage current transformer, power module, Signal conversion module
- Lock: key lock, door lock
- Mechanical interlocking: cable interlocking
- Operation and protection: door frame, phase partition
- Indicator contact: auxiliary contact, alarm contact

Range of Application

HDW3 series air circuit breaker, the rated current is from 400A to 6300A, the rated voltage is 400V/415V, 660/690V, suitable for AC 50/60Hz and mainly used in Power distribution system networks, to distribute electric energy and protect the line and power supply equipment far away from the fault hazard of overload, under voltage, short circuit and single-phase grounding.

The circuit breaker can be widely used in power stations, factories, mines and modern high-rise buildings, especially the intelligent building power distribution system.

Application standard: IEC/EN 60947-2

Normal Working Condition

Environment temperature	Ambient temperature is -5°C ~+40°C(certification); mean value of 24h shall not exceed +35°C. It can also be used at ultimate temperature -40°C ~+70°C(L type, M type controller).
Altitude	≤ 5000m
Electromagnetic interference	Applies to Environment A
Class of pollution	Class of pollution level 3 Installation position shall be vertical, inclination of each direction shall not more than 5°
Installation level	Circuit breaker main circuit and undervoltage trip coil, power transformer primary coil are level IV, auxiliary circuit and control circuit is level III
Transportation condition	Move gentle, do not put upside down, avoid collision

Overview



Front Face

- 1 Open button
- 2 Closing button
- 3 Spring charge mechanism status indicator
 - Spring charged , closing is allowed
 -
 - Spring charged , closing is not allowed
 -
 - Spring released
 -
- 4 Main contact position indicator
 - Open
 - Close
- 5 Spring charge operation handle
- 6 Controller
- 7 Draw in (out) device
- 8 Connection, test and disconnection position indication
- 9 Connect, test and disconnection position limiter
- 10 Rocker storage

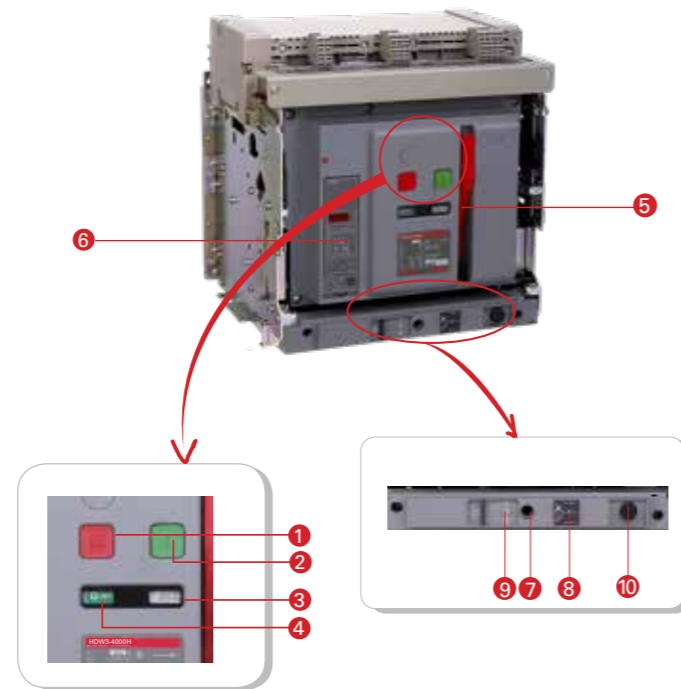

Name plate

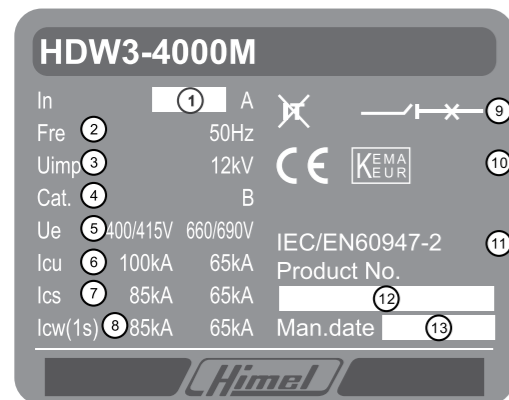

1	Rated Current	8	Rated short-time withstand current
2	Rated frequency	9	Applicability
3	Rated impulse withstand voltage	10	Certificates
4	Utilization category	11	Standard
5	Rated voltage	12	Factory code
6	Rated ultimate short-circuitbreaking capacity	13	Manufacture date
7	Rated service short-circuit breaking capacity		

Overview



HDW3 structure

Draw-out base

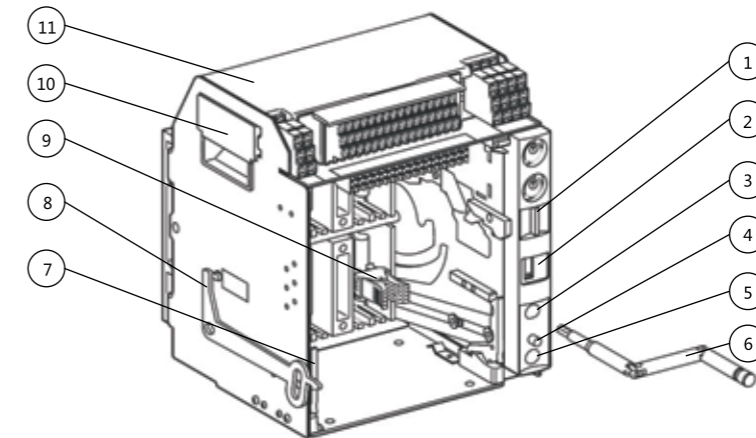

1	key lock	5	rocker storage	9	cluster contact
2	Indicator	6	rocker	10	chassis handle
3	rocker entry	7	draw out handle	11	arc extinguish chamber cover
4	three -position unlocking button	8	door interlock		

Main body

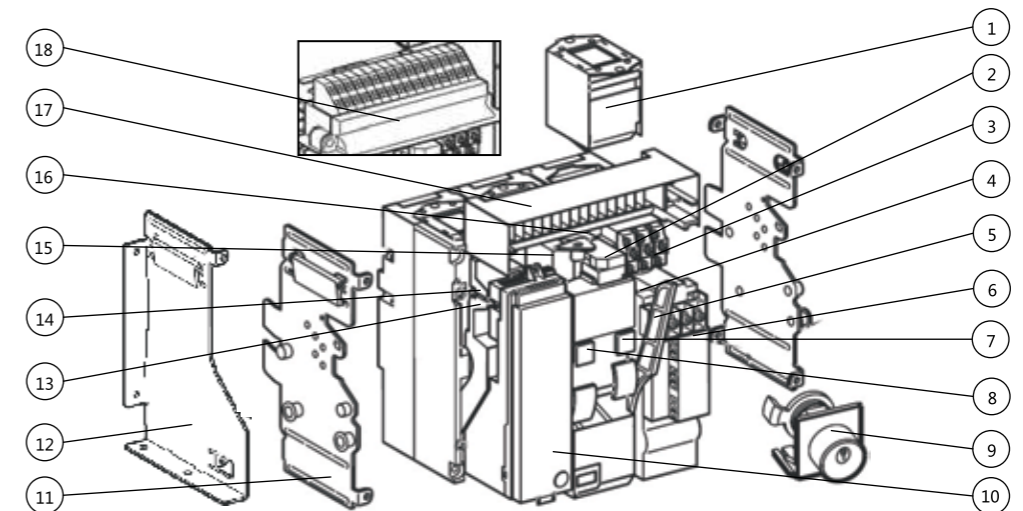

1	arc extinguish chamber	7	Closing button	13	SWT Fault tripping contact
2	XF Closing release	8	Opening button	14	SWT/2 Fault tripping contact or remote restoration
3	OF auxiliary contact	9	Opening button	15	MN undervoltage release
4	PF Ready to close contact	10	iTR controller	16	MX shunt release
5	Energy storage handle	11	Draw-out type side plate	17	Draw-out type secondary circuit terminals
6	MCH motor mechanism	12	Fix type side plate	18	Fixed type secondary circuit terminals

Overview



Technical Parameters

Common features

Pole	3, 4
Rated operational voltage Ue	AC400V/AC415V、 AC660V/ AC690V
Rated insulation voltage Ui	1000 V
Rated impulse withstand voltage Uimp(kV)	12 kV
Rated frequency	50/60 Hz
Suitable for isolation	
Standard	EC 60947-2



Product		HDW3																					
Frame size		1000M	1600M	1600S	2000M	2000S	3200M	3200S	4000M	4000S	6300M	6300S											
Rated current In(A)																							
400		■	■	■																			
630		■	■	■	■	■																	
800		■	■	■	■	■																	
1000		■	■	■	■	■																	
1250			■	■	■	■																	
1600			■	■	■	■		■	■														
2000					■	■	■	■	■														
2500						■	■	■	■														
3200						■	■	■	■														
4000								■	■	■	■												
5000										■	■	■											
6300											■	■	■										
Breaking capacity		400V	690V	400V	690V	400V	690V	400V	690V	400V	690V	400V	690V										
Icu (kA)		42	25	50	35	42	35	80	50	65	40	80	65	65	50	100	65	85	65	120	85	85	75
Ics (kA)		30	25	42	35	42	35	65	40	65	40	65	50	65	50	85	65	85	65	100	75	85	75
Icw(1s) (kA)		30	20	42	35	42	35	65	40	65	40	65	50	65	50	85	65	85	65	85	75	85	75
Service life																							
Mechanical life (with maintenance)		30000		25000				30000				30000				20000						5000	
Mechanical life (without maintenance)		15000		12500				15000				15000				10000							2500
Electrical life(400V)		6500		6000				6500				6500				5000						800	
Electrical life(690V)		4000		4000				4000				4000				3000						500	
Dimension(mm)																							
Draw-out	3P	322*288*329		322*288*330				436*405*425				436*465*425				439*441*428.6					441.5*815*508		
	4P	322*358*329		322*358*330				436*500*425				436*580*425				439*556*428.6						441.5*930*508	
Fixed type	3P	310*276*235		301*276*229				397*364*327				397*428*327				352*422*329.5						/	
	4P	310*346*235		301*346*229				397*459*327				397*543*327				352*537*329.5						/	
Weight(KG)																							
Draw-out type	3P	27.8		34				73.6				93.8				78						233	
	4P	33.1		41				85.5				115				95						271.8	
Fixed type	3P	13		14				41.4				53.4				42						/	
	4P	15.8		17				52				68				52						/	
Tripping time																							
Tripping time with arc extinguishing														≤25ms									
Closing time														≤70ms									

Overview



Temperature derating table						
Frame	Current/temperature	-5°C ~+40°C	+45°C	+50°C	+55°C	+60°C
HDW3-1000	400	400	400	400	400	400
	630	630	630	630	630	550
	800	800	800	800	800	700
	1000	1000	1000	1000	950	900
HDW3-1600	400	400	400	400	400	400
	630	630	630	630	630	550
	800	800	800	800	800	700
	1000	1000	1000	1000	950	900
	1250	1250	1200	1200	1150	1050
HDW3-2000	1600	1600	1550	1500	1450	1350
	630	630	630	630	630	630
	800	800	800	800	800	700
	1000	1000	1000	1000	1000	1000
	1250	1250	1250	1250	1250	1150
	1600	1600	1600	1500	1500	1300
HDW3-3200	2000	2000	1900	1900	1800	1700
	2000	2000	2000	2000	2000	2000
	2500	2500	2400	2300	2200	2200
	3200	3200	3000	3000	2800	2800
HDW3-4000	1600	1600	1600	1600	1600	1600
	2000	2000	2000	2000	2000	2000
	2500	2500	2500	2500	2500	2200
	3200	3200	3200	3200	3000	2500
HDW3-6300	4000	4000	4000	3600	3400	3200
	5000	5000				
	6300	6300				

All derating data is calculated based on experiment and theory, only for selection guide.

Altitude derating table

Altitude below 2000 m will not affect circuit breaker performance. Above this altitude, the diminution of air insulation characteristics and cooling capacity must be considered; The correction coefficients given in the table below are used for installation above 2000 meters:

Altitude (m)	2000	2500	3000	3500	4000	4500	5000
Isolation voltage (V)	1000	910	910	830	830	770	770
Withstand voltage (kV)	12	10.5	10.5	9.5	9.5	9	9
Maximum operation voltage (V)	690	690	690	660	600	600	550
Current on 40 °C	1In	0.98In	0.93In	0.91In	0.87In	0.84In	0.81In

If altitude ove 4000m, please contact the manufacture.

Overview



Power loss and resistance per pole

Power loss is measuring at In,50/60Hz, input/output resistance is the value at cold state in per pole.

Frame	Rated Current (A)	Draw-out type		Fixed type	
		Power Loss (W)	Input/Output resistance($\mu\Omega$)	Power Loss (W)	Input/Output resistance($\mu\Omega$)
1000 1600	400	28.8	42.0	20.5	27
	630	55.6	42.0	32.8	27
	800	98.2	42.0	53.5	27
	1000	153.5	42.0	82.6	27
	1250	250.8	42.0	131.8	27
	1600	460.5	38.0	220	26
2000	630	56.8	48.5	26.5	21.9
	800	73.0	48.5	38.6	21.9
	1000	116.3	38.0	56.9	20.2
	1250	179.8	38.0	90.2	20.2
	1600	294.9	38.0	145.8	20.2
	2000	399.6	33.7	202.5	18
3200	2000	200.6	18.6	99.6	15.8
	2500	310.0	16.2	147.8	14.7
	3200	486.9	15.8	216.3	9.2
4000	1600	390.6	27.5	180.2	13
	2000	480.8	27.0	252.8	13
	2500	600.0	19.0	265	9
	3200	670.0	13.0	423.6	8.5
	4000	900.0	11.8	652.7	8
6300	4000	910.7	9.5	/	/
	5000	940.0	9.0	/	/
	6300	1150.0	8.5	/	/

iRT 326 Controller



Intelligent Controller Introduction

iTR326

iTR326A

iTR326H



	L	M	H
Protection function	Overload protection L	Overload protection L	Overload protection L
	Short-circuit protection with short delay S	Short-circuit protection with short delay S	Short-circuit protection with short delay S
	Short-circuit protection instantaneous I	Short-circuit protection instantaneous I	Short-circuit protection instantaneous I
	Ground protection G	Ground protection G	Ground protection G
	MCR Protection	MCR protection	MCR protection
	HSISC protection	HSISC protection	HSISC protection
			Under voltage protection/alarm
			Overtoltage protection/alarm
			voltage unbalance protection /alarm
			Phase sequence protection/alarm
			Low frequency protection/alarm
			High frequency protection/alarm
			Reverse power protection/alarm
Measurement		Current measurement	Current measurement
			Voltage measurement
			Power measurement
			Frequency measurement
			Harmonics measurement
Auxiliary	Pre-alarm	Pre-alarm	Pre-alarm
	Event record	Self-diagnostic	Self-diagnostic
	Test	Event record	Event record
		Test	Test
Display		LED	LCD
Special function			Load monitoring
			Zone selective interlock
Communication			Modbus

iRT 326 Controller



- 1 Top fixation
- 2 LED indicator light
- 3 Controller name plate
- 4 Bottom fixation
- 5 External connection terminal
- 6 Transformer connector
- 7 Flux/jogging connector



L type (basic type)

Indications

- 1 Alarm lamp
- 2 Over current tripping indication
- 3 Short delay or instantaneous tripping indication
- 4 Ground or leakage current fault tripping indication
- 5 Advanced protection
- 6 Reset button

Settings

- 7 Overload current setting IR
- 8 Over current time delay tR
- 9 Short delay tripping lsd
- 10 Short delay tripping time tsd
- 11 Ground fault tripping Ig
- 12 Ground fault tripping time tg
- 13 Padlock position
- 14 Test button
- 15 Instantaneous tripping li
- 16 Test connection

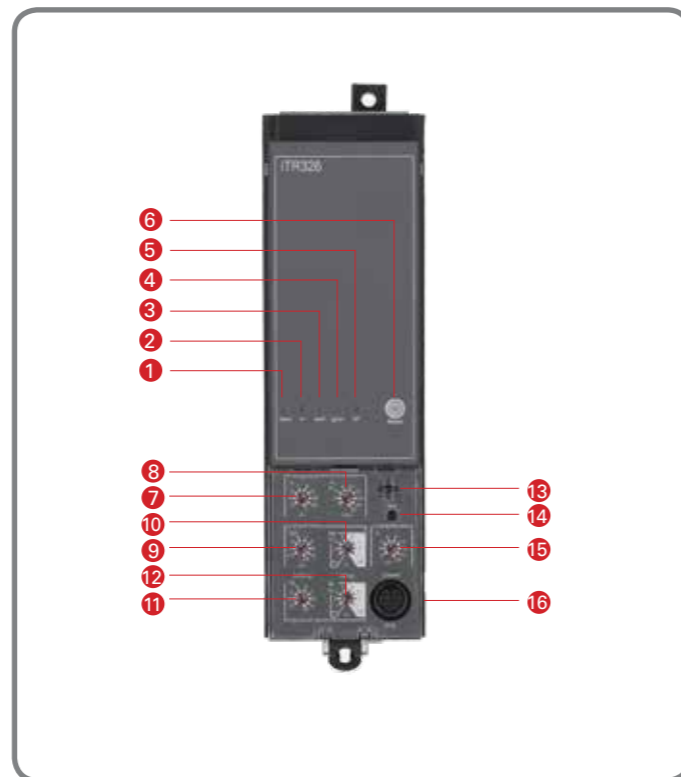

iRT 326 Controller



M type (standard type)

Indications and Settings

- 1 Current unit A
- 2 Current unit kA
- 3 Time unit S
- 4 N phase Current
- 5 A phase Current
- 6 B phase Current
- 7 C phase Current
- 8 Maximum Current
- 9 Tripping indication
- 10 Ground protection
- 11 Long delay protection
- 12 Short delay protection
- 13 Instantaneous protection
- 14 Ground Current set value
- 15 Ground time set value
- 16 Long delay Current set value
- 17 Long delay time set value
- 18 Short delay Current set value
- 19 Short delay time set value
- 20 Instantaneous Current set value
- 21 Tests action state

Navigation keys

- 22 Toggle key
- 23 Set key
- 24 Query key
- 25 Return /clear light
- 26 -/ down page
- 27 +/- up page
- 28 Enter key
- 29 Test key
- 30 Test connection

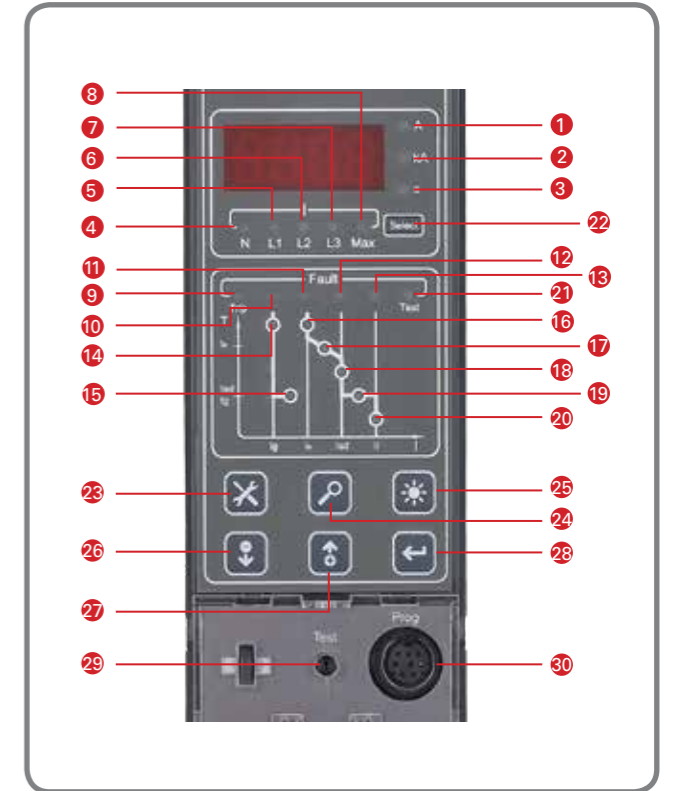

H type (advanced type)

Indications

- 1 Alarm lamp
- 2 Long delay tripping indication
- 3 Short delay or instantaneous tripping indication
- 4 Ground or electric leakage fault tripping indication
- 5 Advanced protection
- 6 Communication function
- 7 Reset button

Navigation keys

- 8 Set key
- 9 Query key
- 10 Return/clear light
- 11 -/ Down page
- 12 +/- Up page
- 13 Enter key

Settings

- 14 Long delay Current setting IR
- 15 Long delay tripping time tR
- 16 Short delay tripping lsd
- 17 Short delay tripping time tsd
- 18 Ground fault tripping Ig
- 19 Ground fault tripping time tg
- 20 Padlock position
- 21 Test button
- 22 Instantaneous tripping Current
- 23 Test connection
- 24 Button description adjustment panel

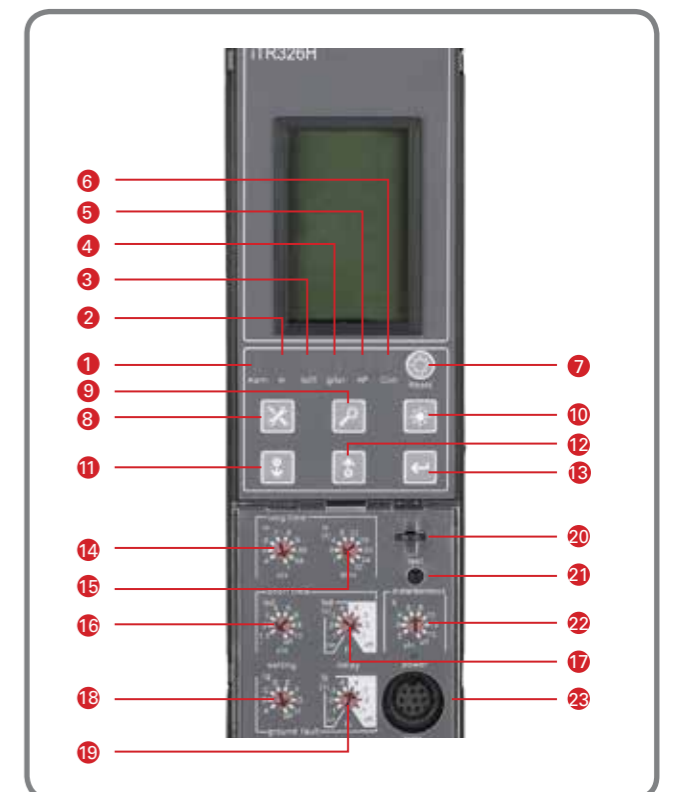



Intelligent Controller Protection

Intelligent controller protection characteristics are inverse time limit and constant time-lag, when fault Current exceeds inverse time limit set value, controller can have delay protection according to the constant time-lag.

Inverse time limit curve conforms to characteristic curve I^2t

Overload protection with long time delay

Threshold of overload protection with long time delay Threshold

$<1.05 I_R$: $>2h$ No tripping;

$>1.2 I_R$: $<1h$ Tripping

$\geq 1.2 I_R$: Tripping with time delay;

I_R Current setting range: $0.4I_n, 0.5I_n, 0.6I_n, 0.7I_n, 0.8I_n, 0.9I_n, 0.95I_n, 0.98I_n, 1.0I_n$

Inverse Time Protection Tripping Characteristics $I^2t: t=(6/N)^2 * t_R$

Setting electric current	Action time (s)								
$1.5 I_R$	16s	32s	64s	128s	192s	256s	320s	384s	480s
$2 I_R$	9s	18s	36s	72s	108s	144s	180s	216s	270s
$6 I_R$	1s	2s	4s	8s	12s	16s	20s	24s	30s

Note: N---- Overload current is divided from the setting current I/I_R

t---- time delay of overload current

t_R ---- time delay of setting value

Allowed tolerance of the tripping time $\pm 10\%$

Short circuit protection with short time delay

Threshold of Short circuit protection with short time delay

$<0.9 I_{sd}$: No tripping

$>1.1 I_{sd}$: Tripping;

$\geq 1.1 I_{sd}$: Tripping with time delay

I_{sd} setting range: $1.5 I_R, 2 I_R, 3 I_R, 4 I_R, 5 I_R, 6 I_R, 8 I_R, 10 I_R + OFF$

Short circuit current	Tripping Time		Formula of tripping curve		$I^2t: t=(8I_R)^2 tsd$			
$I_{sd} < 8I_R$	Inverse time protection	Setting time s	0.1	0.2	0.3	0.4		
		Min. s	0.08	0.14	0.23	0.35		
$I \geq 1.1I_{sd}$	constant time delay protection	Setting time s	0.1	0.2	0.3	0.4		
		Max. s	0.14	0.2	0.32	0.5		

Note: I_{sd} --- setting short circuit protection value

I---- short circuit current

I_R ---- setting current

t---- tripping time of short circuit

tsd ---- setting time delay of short circuit protection

Allowed tolerance of the tripping time $\pm 20\%$

Short Circuit Instantaneous Protection

Short Circuit Instantaneous Protection Action Threshold

$<0.85 I_i$: No tripping

$>1.15 I_i$: tripping

Instantaneous action current setting: $2I_n, 3I_n, 4I_n, 6I_n, 8I_n, 10I_n, 12I_n, 15I_n + OFF$

Note: tolerance of the tripping time $\leq 50ms$

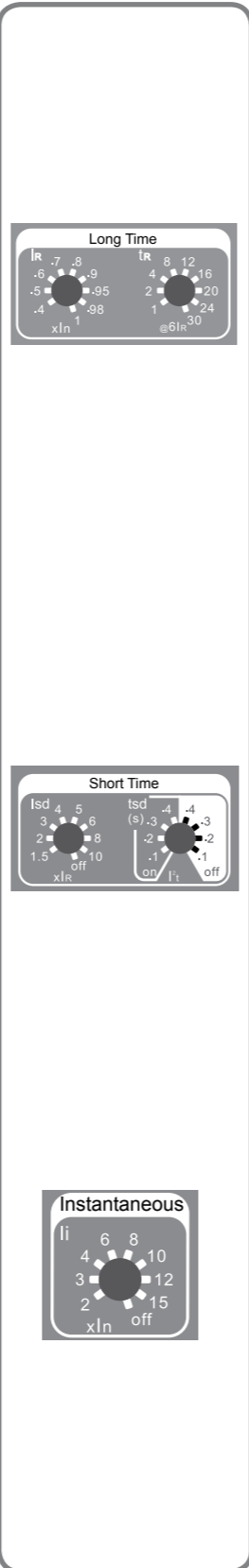

Ground Fault Protection Action

Ground Fault Protection Action Threshold

$<0.9 I_g$: No tripping

$>1.1 I_g$: tripping

$\geq 1.1 I_g$: Tripping with time delay

Current	A	B	C	D	E	F	G	H	OFF
$I_n < 1250$	$0.2I_n$	$0.3I_n$	$0.4I_n$	$0.5I_n$	$0.6I_n$	$0.8I_n$	$0.9I_n$	I_n	
$I_n \geq 1250$	500A	600A	700A	800A	900A	1000A	1100A	1200A	

Ground current	tripping time	Inverse time protection formula of tripping curve	$t = \frac{(I_g)^2}{I^2} \times t_g$			
			Setting time	0.1	0.2	0.3
tg(s)	constant time delay protection	Setting time	0.1	0.2	0.3	0.4
		Min. (s)	0.08	0.14	0.23	0.35
		Max. (s)	0.14	0.2	0.32	0.5

Note: I_g ground protection setting, when $I_n \geq 1250A, I_J = 1200A$, when $I_n < 1250A, I_J = I_n$

I Ground fault current

T tripping time with time delay

t_g setting tripping time of ground fault

Allowed tolerance of the inverse tripping time $\pm 20\%$

Default setting

Tripping curves I^2t	over current		short circuit with time delay		Inst.	Ground fault		Thermal memory
	I_R	t_R	I_{sd}	t_s	I_i	I_g	t_g	
	$1I_n$	30s	$6I_n$	0.2s	$10I_n$	3P - "OFF" 4P - "G"	0.4s	20min





HDW3 Breaker Accessory Indicator

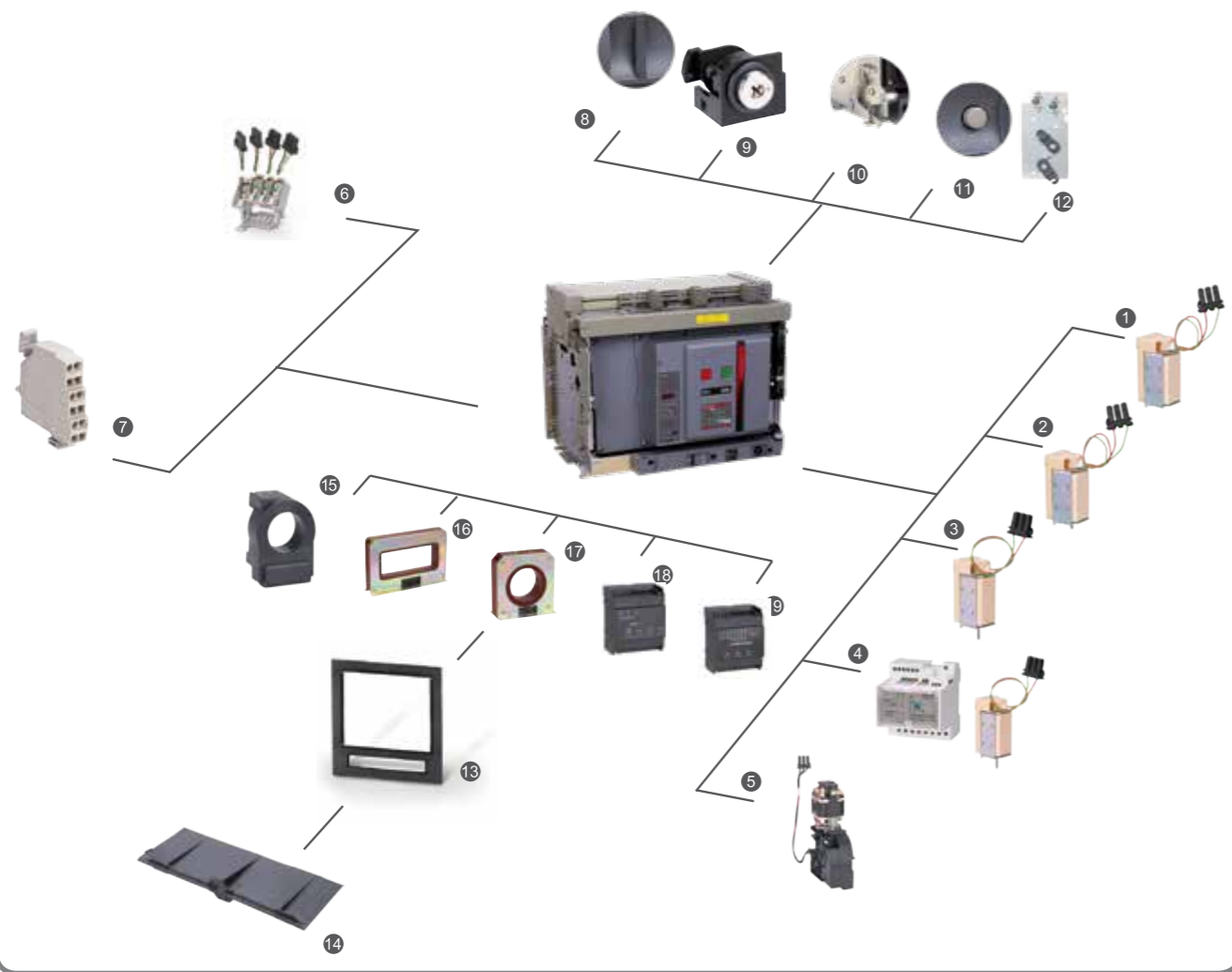

Remote Operation	Indication Contact	Lock and Connection	Operation and protection	Controller accessories
1 Shunt coil	6 Auxiliary switch OF	8 Padlock	13 Door frame	15 N phase external transformer
2 Closing coil	7 Secondary terminal	9 Key lock	14 Phase partition	16 Leakage current transformer
3 Undervoltage release		10 Door lock		17 Ground transformer
4 Undervoltage delay release		11 Connection, separation, test position locking mechanism		18 Power module
5 Motor operating mechanism		12 Mechanical interlocking		19 Signal conversion module

Note: 1000AF/1600AF the accessory is same parts.



Remote Operation

Shunt release MX

After circuit breaker is switched on, when shunt release is under specified power supply voltage, disconnect the circuit breaker instantaneously by remote operation.

- Rated control supply voltage AC220/AC230V, AC380/AC400V, DC220V, DC110V
- Operation voltage (0.7-1.1) Us
- Break-time: 50 ± 10ms

Closing coil XF

After spring be fully charged, Closing coil can make the circuit breaker close under the specified power supply voltage and can have remote operation.

- Rated control supply voltage AC220/AC230V, AC380/AC400V, DC220V, DC110V
- Operating voltage: (0.85-1.1) Us
- Closing time: 55 ± 10ms

Undervoltage release MN

After the breaker switch on , Undervoltage release will tripped circuit breaker instantaneously when power supply drop down between 70%-35% Ue.

The breaker can be switched on when the power supply is 85% Ue.

- Rated control supply voltage AC220/AC230V, AC380/AC400V
- Operation voltage: (0.35-0.7) Ue
- Reliable Closing voltage: (0.85-1.1) Ue
- Non closing voltage: ≤ 0.35Ue
- Delay time: 0.5s, 1s, 1.5s, 3s (1600, 4000), 1s, 3s, 5s (2000, 3200)

Under voltage release with time delay MNR

The MNR (when voltage drop) will switched off the circuit breaker with certain time delay , 0.5s, 1s, 1.5s, 3s(1600, 4000), 1s, 3s, and 5s (2000, 3200).

Motor Operating Mechanism MCH

When the circuit breaker is disconnected and power supply is available, motor operating mechanism can automatically charge the spring of the circuit breaker, so that the circuit breaker is disconnected or closed under the action of shunt excitation, undervoltage trip and closing electromagnet. In the absence of power supply, the handle can be used to store energy for the circuit breaker.

- Rated control supply voltage AC220/AC230V, AC380/AC400V, DC220V, DC110V
- Operation voltage: (0.85-1.1) Us
- Power dissipation: 75W/180W(1600), 85W(2000), 110W(3200), 180W(4000)
- Spring charging : <5s
- Utilization category: AC15, DC13



Accessory and Overview



Indication Contacts

Auxiliary Contact OF

4NO+4NC by default
 (4000H can provide 8NO+8NC and 6NO+6NC, 2000, 3200 also can provide 6NO+6NC)
 It can be used to monitor the status of circuit breakers, such as connecting circuit breaker position indicator and disconnecting indicator
 Rated thermal current I_{th}: AC380V/AC400V 0.75A, DC220V 0.15A, AC220V/AC230V 1.3A

Lock

Drawer Padlock

Lock provided by user
 If the padlock is provided by the user himself, and the circuit breaker is in the position of "separation", pull out the padlock plate. After locking, the crank handle cannot be inserted.

Keylock

The breaker can be locked by key lock in switch off position. When the key is inserted into the lock and turned on to "on" position, the breaker can be allowed to switched on. (Key turned off or removed from lock, breaker can be switched on)
 There are 3 options of key lock available (available for 2 Breaker Interlock & 3 Breaker Interlock)

• One lock one key

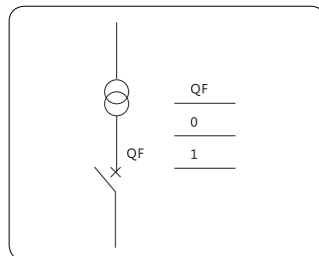

• Two locks one key

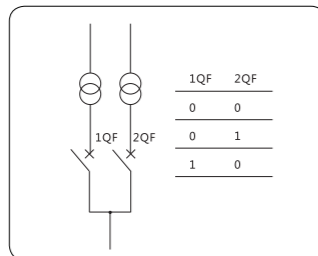

• Three locks two key

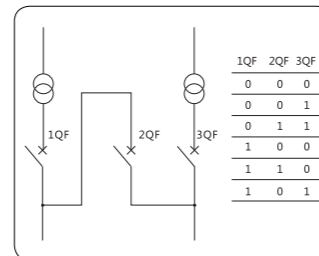

Drawer Position Locking Mechanism

It is a locker when the breaker is in the position of "connection," "test," and "disconnection" in a drawer type circuit breaker. Circuit breaker three positions are indicated through the indicator, the advance and retreat handle is locked in the exact position and is unlocked through the reset button.

Door Lock

It is suitable for cabinet frame of 2000 and 3200
 In drawer type circuit breaker, it is installed on the side of circuit breaker and linkages to distribution cabinet door. It can not be opened when the circuit breaker is connected or tested. The cabinet door can be opened in the open position. It can prevent the circuit breaker from slipping and causing damage.



Accessory and Overview



Operation and Protection

Mechanical interlock

- The mechanical interlocks are available for fixed and drawout circuit breakers, enabling the direct interlocking of the breakers, mounted side by side or stacked.
- The interlocking systems are available in one configuration for 2 breakers and in three others for 3 breakers.

Door Frame

- The door frame installed on the door of distribution cabinet can increase IP protection level to IP40
- It is applicable to stationary type and drawer type.

Phase Partition

- The insulation board installed in the middle of the breaker bus can increase the creepage distance and improve the insulation capacity

Controller Accessories

N Phase External Transformer

In a 3P+N grounding mode, an External transformer used to measure neutral phase current is harnessed to the wiring bus by the user

Ground Transformer

- A special External transformer is used to measure the earth current when the ground current returns. It can protect the upper and lower ground faults of the circuit breaker at the same time
- It is only applicable to iTR326H controller

Leakage Current Transformer

- When the earth protection is leakage type, a special rectangular transformer is added
- It is only applicable to iTR326H controller

Power Module

- It can provide auxiliary power for intelligent controller at the circuit of AC220V/AC230V, AC380V/AC400V, DC220V, DC110V
- Input is AC220V/AC230V, AC400V/AC380V, DC220V, DC110V, output is DC24V
 The input fluctuation range is 20%, the output fluctuation range is 5%, and the total power of 4 sets of DC24V is 7W.



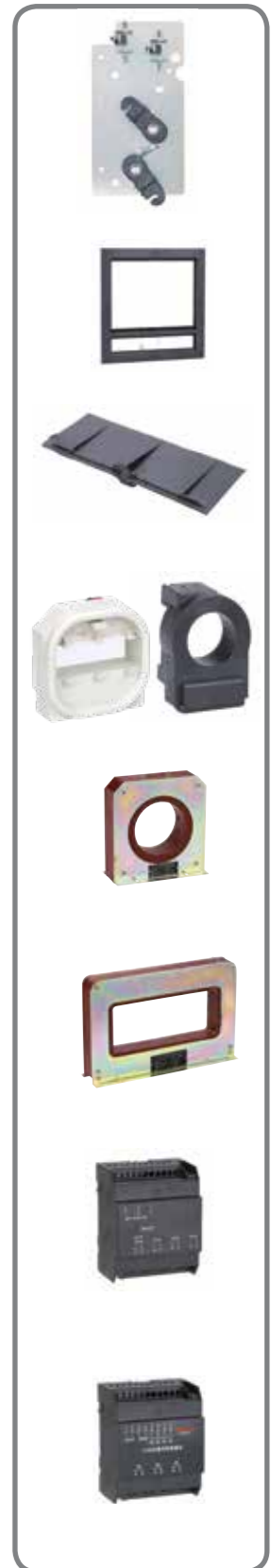

Signal Conversion Module

- Output signal unit is applicable to communication function, such as regional interlocking, signal processing of four remote functions or fault alarm or indication, etc.
- It is only applicable to iTR326H controller





Accessory Coding

	Accessory coding	Accessory name
Controller 	HDW3TUL	Controller iTR326
	HDW3TUM	Controller iTR326A
	HDW3TUH	Controller iTR326H
	HTE100C	HDW3 Test Kits
Remote Operation		
Shunt release 	HDW3MX12A	Shunt tripper AC230V(CDW3-2000AF/3200AF/6300AF)
	HDW3MX13A	Shunt tripper AC400V(CDW3-2000AF/3200AF/6300AF)
	HDW3MX12D	Shunt tripper DC220V(CDW3-2000AF/3200AF/6300AF)
	HDW3MX11D	Shunt tripper DC110V(CDW3-2000AF/3200AF/6300AF)
	HDW3MX2A	Shunt tripper AC230V(CDW3-1600AF/4000AF)
	HDW3MX3A	Shunt tripper AC400V(CDW3-1600AF/4000AF)
	HDW3MX2D	Shunt tripper DC220V(CDW3-1600AF/4000AF)
	HDW3MX1D	Shunt tripper DC110V(CDW3-1600AF/4000AF)
Closing Coil 	HDW3XF12A	Closing tripper AC230V(CDW3-2000AF/3200AF/6300AF)
	HDW3XF13A	Closing tripper AC400V(CDW3-2000AF/3200AF/6300AF)
	HDW3XF12D	Closing tripper DC220V(CDW3-2000AF/3200AF/6300AF)
	HDW3XF11D	Closing tripper DC110V(CDW3-2000AF/3200AF/6300AF)
	HDW3XF2A	Closing tripper AC230V(CDW3-1600AF/4000AF)
	HDW3XF3A	Closing tripper AC400V(CDW3-1600AF/4000AF)
	HDW3XF2D	Closing tripper DC220V(CDW3-1600AF/4000AF)
HDW3XF1D	Closing tripper DC110V(CDW3-1600AF/4000AF)	
Undervoltage release 	HDW3MN12A	Undervoltage tripper AC230V(CDW3-2000AF/3200AF/6300AF)
	HDW3MN13A	Undervoltage tripper AC400V(CDW3-2000AF/3200AF/6300AF)
	HDW3MN2A	Undervoltage tripper AC230V(CDW3-1600AF/4000AF)
Undervoltage Delay release 	HDW3MNR12A	Undervoltage delay tripper AC230V(CDW3-2000AF/3200AF/6300AF)
	HDW3MNR13A	Undervoltage delay tripper AC400V(CDW3-2000AF/3200AF/6300AF)
	HDW3MNR2A	Undervoltage delay tripper AC230V(CDW3-1600AF/4000AF)
	HDW3MNR3A	Undervoltage delay tripper AC400V(CDW3-1600AF/4000AF)



NOTE:
 HDW3 Test Kits can test overload, short circuit, instantaneous, ground trip on site.
 HDW3 Test kits adapt with L & H type controller, Do not test on M type controller (iTR326A) If you have any require of test kits please contact with local HIMEL office

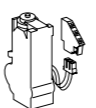
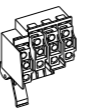
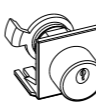
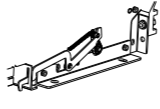
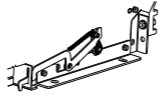

Remote Operation	Accessory Coding	Accessory Name
Motor Mechanism 	HDW3MCH202A	Motor mechanism AC230V(HDW3-2000AF)
	HDW3MCH203A	Motor mechanism AC400V(HDW3-2000AF)
	HDW3MCH202D	Motor mechanism DC220V(HDW3-2000AF)
	HDW3MCH201D	Motor mechanism DC110V(HDW3-2000AF)
	HDW3MCH322A	Motor mechanism AC230V(HDW3-3200AF)
	HDW3MCH323A	Motor mechanism AC400V(HDW3-3200AF)
	HDW3MCH322D	Motor mechanism DC220V(HDW3-3200AF)
	HDW3MCH321D	Motor mechanism DC110V(HDW3-3200AF)
	HDW3MCH162A	Motor mechanism AC230V(HDW3-1600AF)
	HDW3MCH163A	Motor mechanism AC400V(HDW3-1600AF)
	HDW3MCH162D	Motor mechanism DC220V(HDW3-1600AF)
	HDW3MCH161D	Motor mechanism DC110V(HDW3-1600AF)
	HDW3MCH402A	Motor mechanism AC230V(HDW3-4000AF)
	HDW3MCH403A	Motor mechanism AC400V(HDW3-4000AF)
	HDW3MCH402D	Motor mechanism DC220V(HDW3-4000AF)
	HDW3MCH401D	Motor mechanism DC110V(HDW3-4000AF)
Indicator Contact Auxiliary Contact 	HDW3MCH632A	Motor mechanism AC230V(HDW3-6300AF)
	HDW3MCH633A	Motor mechanism AC400V(HDW3-6300AF)
	HDW3MCH632D	Motor mechanism DC220V(HDW3-6300AF)
Lock Key Lock 	HDW3OF1644	Auxiliary contact 4 open 4 close (HDW3-1600AF)
	HDW3OF3266	Auxiliary contact 6 open 6 close (HDW3-2000/3200/6300AF)
	HDW3OF4044	Auxiliary contact 4 open 4 close (HDW3-4000AF)
Door Lock 	HDW316L3	3 locks 2 keys HDW3-1600AF
	HDW316L2	2 locks 1 key HDW3-1600AF
	HDW316L1	1 lock 1 key HDW3-1600AF
	HDW3L3	3 locks 2 keys HDW3-2000AF/3200AF/6300AF
	HDW3L2	2 locks 1 key HDW3-2000AF/3200AF/6300AF
	HDW3L1	1 lock 1 key HDW3-2000AF/3200AF/6300AF
	HDW340L3	3 locks 2 keys HDW3-4000AF
	HDW340L2	2 locks 1 key HDW3-4000AF
HDW340L1	1 lock 1 key HDW3-4000AF	
Door Lock 	HDW316DLR	Drawout type Door interlock HDW3-1600AF
	HDW320DLR	Drawout type Door interlock HDW3-2000AF
	HDW332DLR	Drawout type Door interlock HDW3-3200AF
	HDW340DLR	Drawout type Door interlock HDW3-4000AF
	HDW363DLR	Drawout type Door interlock HDW3-6300AF



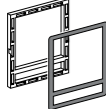
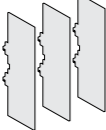
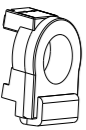

NOTE: Door interlock is not available for fix type HDW3

Accessory and Overview

Operation and Protection	Accessory Coding	Accessory Name
	HDW316FCDP	Fixed type door frame HDW3-1600AF
	HDW316DCDP	Drawer type door frame HDW3-1600AF
	HDW320FCDP	Fixed type door frame HDW3-2000AF
	HDW320DCDP	Drawer type door frame HDW3-2000AF
	HDW332FCDP	Fixed type door frame HDW3-3200AF
	HDW332DCDP	Drawer type door frame HDW3-3200AF
	HDW340FCDP	Fixed type door frame HDW3-4000AF
	HDW340DCDP	Drawer type door frame HDW3-4000AF
	HDW363DCDP	Drawer type door frame HDW3-6300AF
	HDW316FD	Fixed type phase partition 3PHDW3-1600AF
	HDW316DD	Drawer type phase partition 3PHDW3-1600AF
	HDW332FD	Fixed type phase partition 3PHDW3-2000/3200/6300AF
	HDW332DD	Drawer type phase partition 3PHDW3-2000/3200/6300AF
	HDW340FD	Fixed type phase partition 3PHDW3-4000AF
	HDW340DD	Drawer type phase partition 3PHDW3-4000AF
	HDW3164FD	Fixed type phase partition 4PHDW3-1600AF
	HDW3164DD	Drawer type phase partition 4PHDW3-1600AF
	HDW3324FD	Fixed type phase partition 4PHDW3-2000/3200/6300AF
	HDW3324DD	Drawer type phase partition 4PHDW3-2000/3200/6300AF
	HDW3404FD	Fixed type phase partition 4PHDW3-4000A
	HDW3404DD	Drawer type phase partition 4PDW3-4000AF
	Intelligent Controller Accessories	
	HDW31604NCT	N phase External mutual inductor HDW3-1600AF/400A
	HDW3160616NCT	N phase External mutual inductor HDW3-1600AF/630-1600A
	HDW3200608NCT	N phase External mutual inductor HDW3-2000AF/630-800A
	HDW3201020NCT	N phase External mutual inductor HDW3-2000AF/1000-2000A
	HDW332NCT	N phase External mutual inductor HDW3-3200AF/2000-3200A
	HDW340NCT	N phase External mutual inductor HDW3-4000AF/1600-4000A
	HDW363NCT	N phase External mutual inductor HDW3-6300SF
	HDW3ZT100-400	Ground mutual inductor HDW3-400A (is only applicable to type H Controller)
	HDW3ZT100-630	Ground mutual inductor HDW3-630A (is only applicable to type H Controller)
	HDW3ZT100-800	Ground mutual inductor HDW3-800A (is only applicable to type H Controller)
	HDW3ZT100-1000	Ground mutual inductor HDW3-1000A (is only applicable to type H Controller)
	HDW3ZT100-1250	Ground mutual inductor HDW3-1250A (is only applicable to type H Controller)
	HDW3ZT100-1600	Ground mutual inductor HDW3-1600A (is only applicable to type H Controller)
	HDW3ZT100-2000	Ground mutual inductor HDW3-2000A (is only applicable to type H Controller)
	HDW3ZT100-2500	Ground mutual inductor HDW3-2500A (is only applicable to type H Controller)
	HDW3ZT100-3200	Ground mutual inductor HDW3-3200A (is only applicable to type H Controller)
	HDW3ZT100-6300	Ground mutual inductor HDW3-6300A(is only applicable to type H Controller)

Accessory and Overview

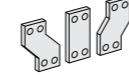

Intelligent controller accessories	Accessory coding	Accessory name
	HDW3ZCT1	Leakage current mutual inductor HDW3 (is only applicable to H controller)
	HDW3TR	Signal conversion module (H communication, regional interlocking, 4 remote controllers)
	iAPU334	Power module input AC220V-AC400V / output 24VDC
	iAPU332D	Power module input DC220/DC110V / output 24VDC
Mechanical interlocking		
	HDW316FL2	Fixed type cable interlocking (2 sets) HDW3-1600AF
	HDW332FL2	Fixed type cable interlocking (2 sets) HDW3-2000/3200/6300AF
	HDW340FL2	Fixed type cable interlocking (2 sets) HDW3-4000AF
	HDW332FL3	Fixed type cable interlocking (3 sets) HDW3-2000/3200/6300AF
	HDW340FL3	Fixed type cable interlocking (3 sets) HDW3-4000AF
	HDW316DL2	Drawer type cable interlocking (2 sets) HDW3-1600AF
	HDW332DL2	Drawer type cable interlocking (2 sets) HDW3-2000/3200/6300AF
	HDW340DL2	Drawer type cable interlocking (2 sets) HDW3-4000AF
	HDW332DL3	Drawer type cable interlocking (3 sets) HDW3-2000/3200/6300AF
	HDW340DL3	Drawer type cable interlocking (3 sets) HDW3-4000AF
Connection accessory		
	HDW3V3	Vertical L adaptor 3PW3-2000 (2000A Below)
	HDW3V4	Vertical L adaptor 4PW3-2000 (2000A Below)
	HDW3S3	Expanding terminal 3P (1600N)
	HDW3S4	Expanding terminal 4P (1600N)

Note

1. HDW3 series package is default with Power module / Door frame / Phase partition / Auxiliary contact.
2. shunt release / closing coil / under voltage release , 1600/4000 is common used , 2000 /3200/6300 is comon used.
3. Door interlok requirment , please contact with local office.

Installation Dimension



Busbar connection

Draw-out and fixed type

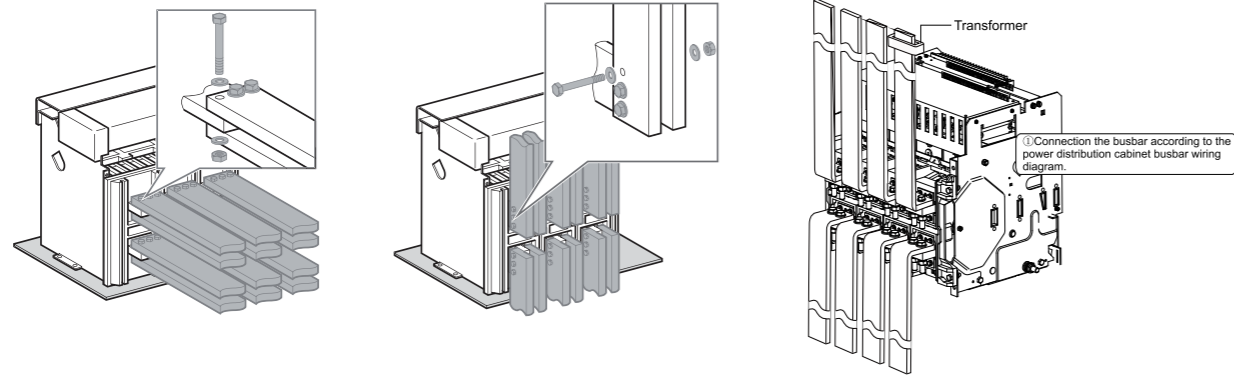

Remark: vertical connection only for 1600AF/4000AF

Safety clearances

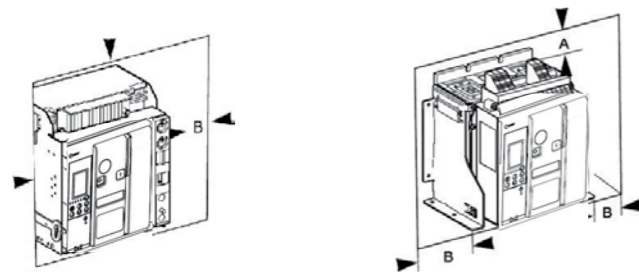

Safety clearances(mm)	Draw-out type*		Fixed type	
	A	B	A	B
Non-conductor	0	10	0	0
Metals	0	10	0	0
Energized conductor	30	60	100	60

*only suitable for 1000AF and 1600AF

Rear connection

Horizontal

Vertical

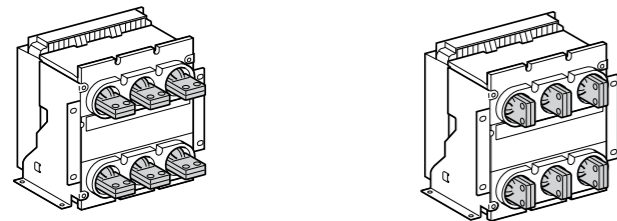

Note:

1. All shell frames are provided with horizontal connections, only 1600&4000 providing vertical connections
2. 1600 horizontal and vertical connections can be made by rotating the bus
3. The vertical connection of 2000 shell frame can be realized by optional vertical L adapter, which is only limited below 2000A.

Installation Dimension



Recommended dimension of busbar

Busbar type table in different temperatures

Busbar max temperature

Material of busbar is copper

Frame (AF)	Rated Current (A)	ambient temperature +40°C				ambient temperature +50°C				ambient temperature +60°C			
		5mm Busbar		10mm Busbar		5mm Busbar		10mm Busbar		5mm Busbar		10mm Busbar	
		Quantity	dimension	Quantity	dimension	Quantity	dimension	Quantity	dimension	Quantity	dimension	Quantity	dimension
1000	400	2	30*5	1	30*10	2	30*5	1	30*10	2	30*5	1	30*10
	630	2	40*5	1	40*10	2	40*5	1	40*10	2	40*5	1	40*10
	800	2	50*5	1	50*10	2	50*5	1	50*10	2	50*5	1	50*10
	1000	3	50*5	2	40*10	3	50*5	2	40*10	4	50*5	2	50*10
1600	400	2	30*5	1	30*10	2	30*5	1	30*10	2	30*5	1	30*10
	630	2	40*5	1	40*10	2	40*5	1	40*10	2	40*5	1	40*10
	800	2	50*5	1	50*10	2	50*5	1	50*10	2	50*5	1	50*10
	1000	3	50*5	2	40*10	3	50*5	2	40*10	3	50*5	2	40*10
2000	1250	4	40*5	2	40*10	4	50*5	2	50*10	4	50*5	2	50*10
	1600	4	50*5	2	50*10	4	50*5	2	50*10	4	50*5	2	50*10
	630	2	40*5	1	40*10	2	50*5	1	50*10	2	60*5	1	60*5
	800	2	50*5	1	50*10	2	50*5	1	50*10	2	60*5	1	60*5
3200	1000	3	50*5	2	40*10	3	50*5	2	40*10	3	60*5	2	50*5
	1250	3	60*5	2	50*10	3	60*5	2	50*10	3	60*5	2	50*5
	1600	4	60*5	2	60*10	4	60*5	2	60*10	4	60*5	2	60*5
	2000	6	60*5	3	60*10	6	60*5	3	60*10	6	60*5	3	60*5
4000	2000	4	100*5	2	100*10	4	100*5	2	100*10	4	100*5	2	100*10
	2500	4	100*5	2	100*10	4	100*5	2	100*10	4	100*5	2	100*10
	3200	8	100*5	4	100*10	8	100*5	4	100*10	8	100*5	4	100*10
	1600	2	100*5	1	100*10	2	100*5	1	100*10	2	100*5	1	100*10
6300	2000	4	100*5	2	100*10	4	100*5	2	100*10	4	100*5	2	100*10
	2500	4	100*5	2	100*10	4	100*5	2	100*10	4	100*5	2	100*10
	3200	8	100*5	4	100*10	8	100*5	4	100*10	8	100*5	4	100*10
	4000			5	100*10			5	100*10			6	100*10
6300	4000			5	100*10			5	100*10			6	100*10
	5000			7	100*10			7	100*10			8	100*10
	6300			8	100*10			8	100*10				

Screw table

	1000M	1600M&S	2000M&S	3200M&S	4000M&S	6300M&S
Screw dimension	M10	M10	M12	M12	M10	M12
Torque	50N·m	50N·m	95N·m	95N·m	50N·m	95N·m

Holes dimension on busbar and installation torque

	1600M&S	1600M&S	2000M&S	3200M&S	4000M&S	6300M&S
Hole dimension	Ø11	Ø11	Ø13	Ø13	Ø11	Ø13
Torque	50N·m	50N·m	95N·m	95N·m	50N·m	95N·m

Installation Dimension



Dimensions HDW3-1000 Draw-out type 3P&4P

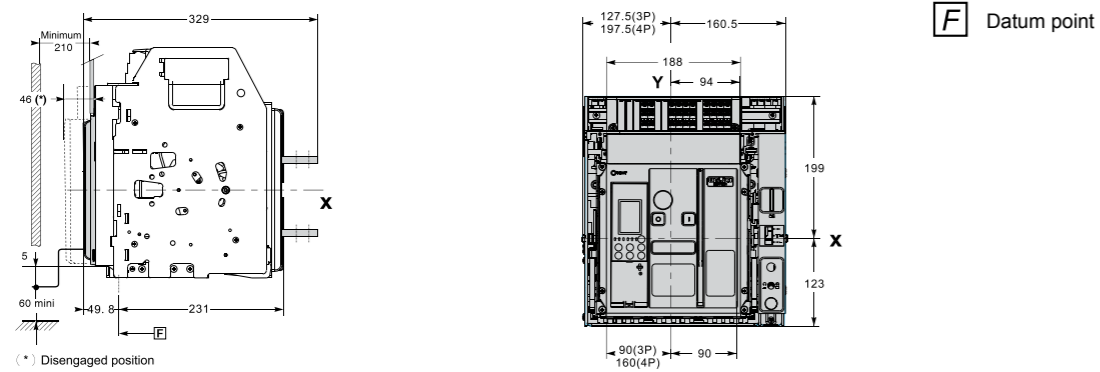

Horizontal Installation

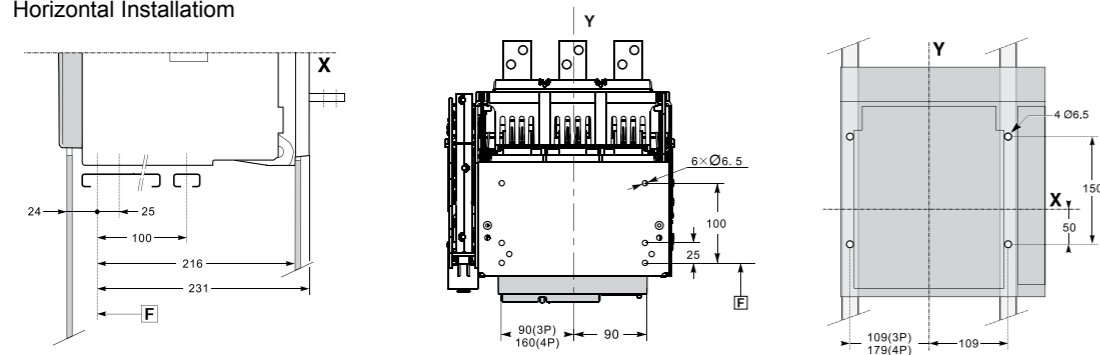

Safety clearance

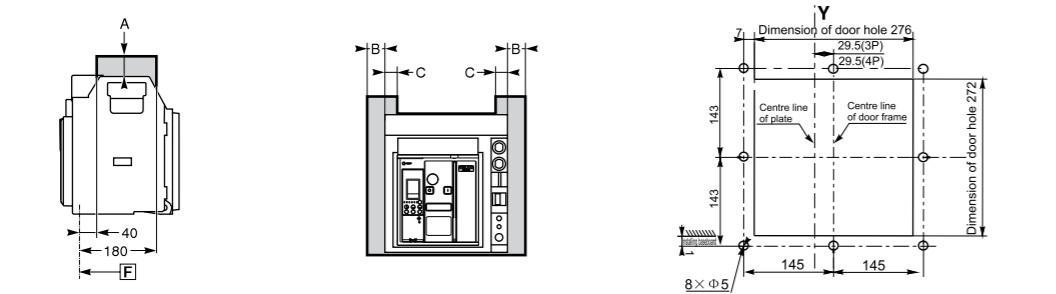

F Datum point

Safety clearance(mm)	Draw-out type		
	A	B	C
Non-conductor	0	10	0
Metals	0	10	0
Energized conductor	30	60	30

Installation Dimension



Dimensions HDW3-1000 Draw-out type 3P&4P

Horizontal connection

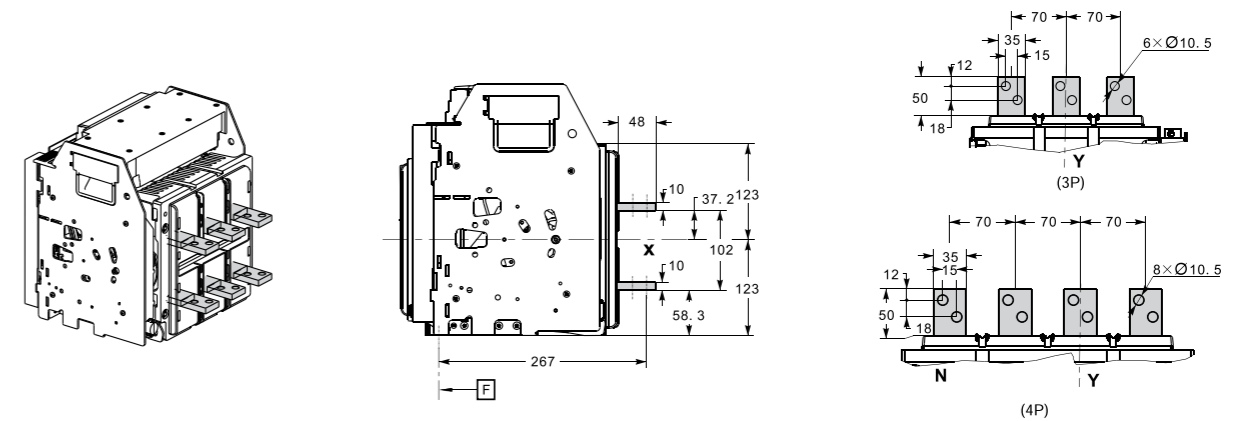

connection with expanding terminals

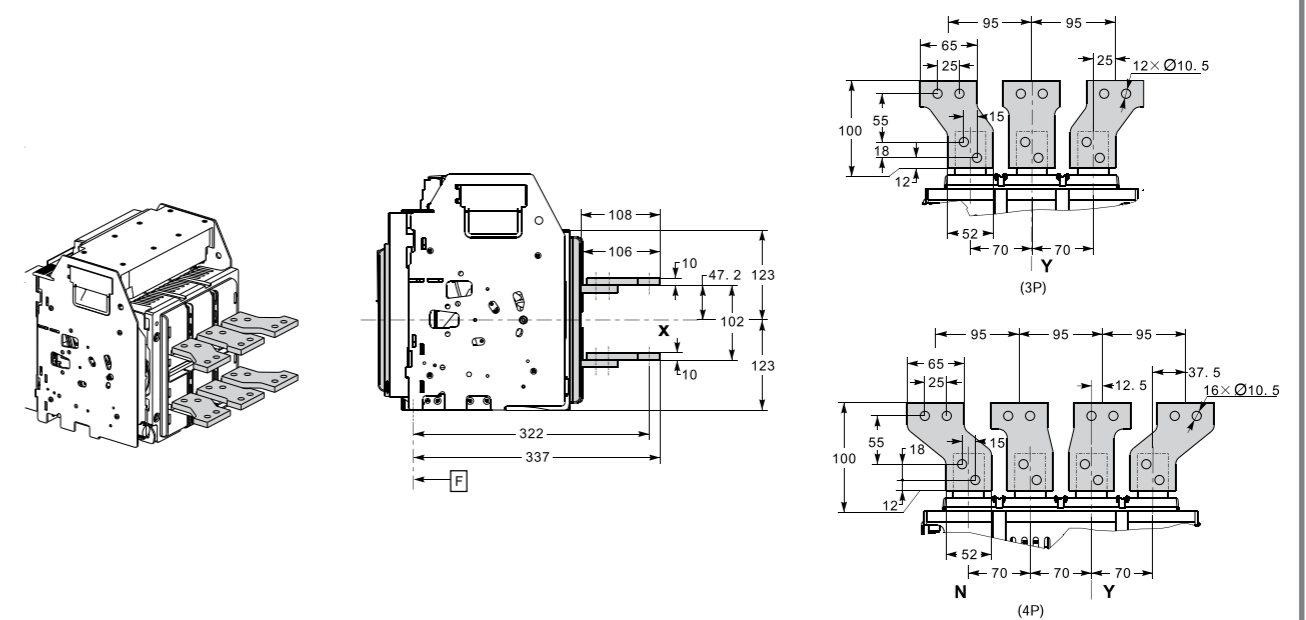

F Datum point

Installation Dimension



Dimensions HDW3-1000 Fixed type 3P&4P

F Datum point

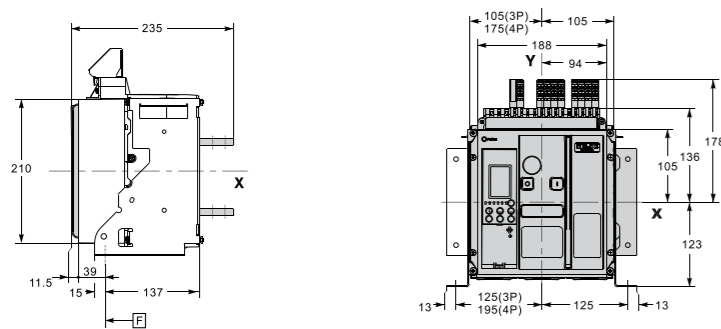

Horizontal Installation

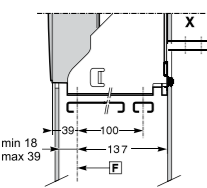

Vertical installation

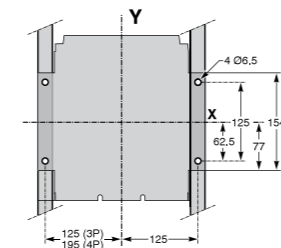
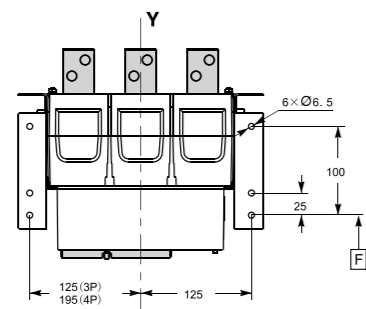

Safety clearance

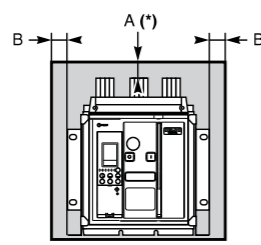
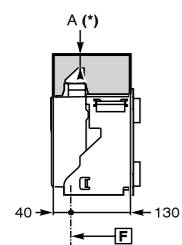

Holes size on door

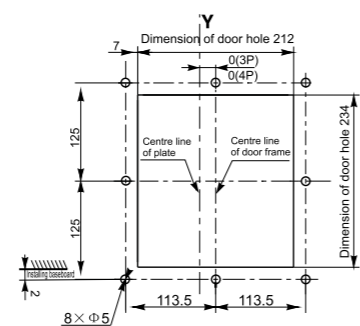

F Datum point

Safety clearance(mm)	Fixed type	
	A	B
Non-conductor	0	0
Metals	0	0
Energized conductor	100	60

Installation Dimension



Dimensions HDW3-1000 Fixed type 3P&4P

Horizontal connection

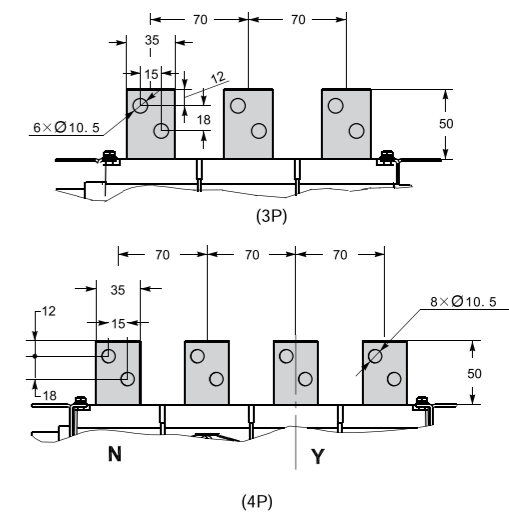
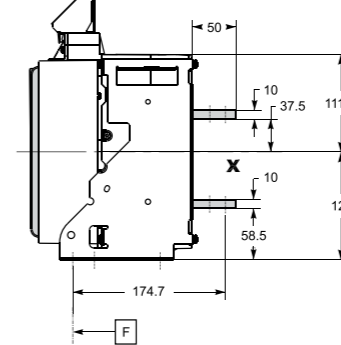
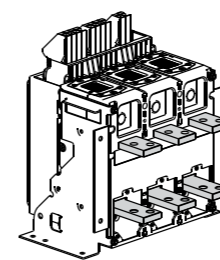

connection with expanding terminals

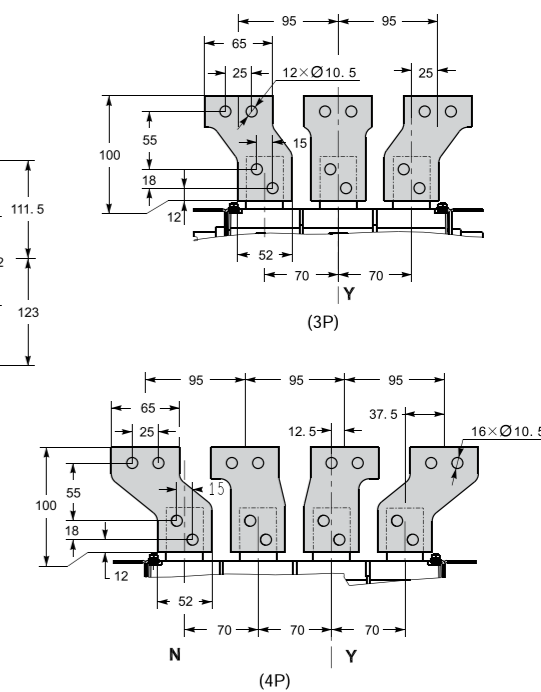
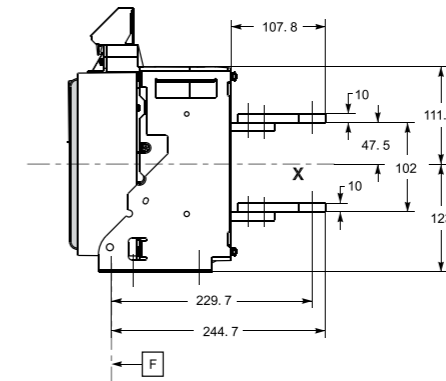
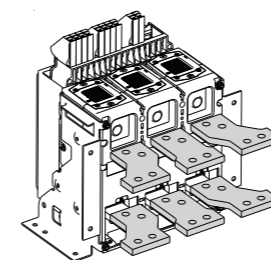

F Datum point

Installation Dimension



Dimensions HDW3-1600 Fixed type 3P&4P

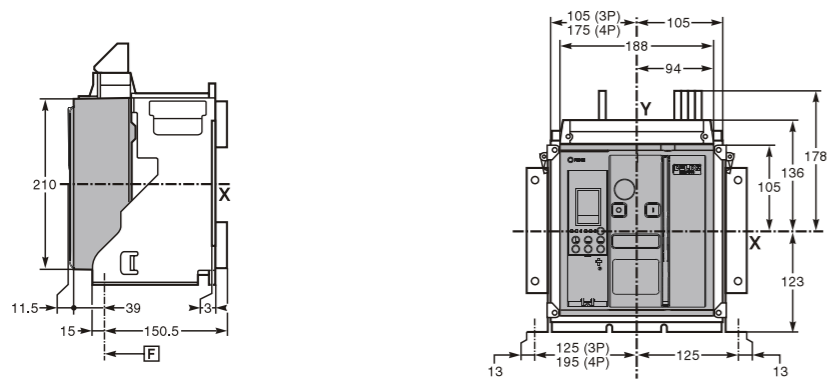

Horizontal Fixed (On a substrate or track)

Vertical Fixed diagram (On the back or rack)

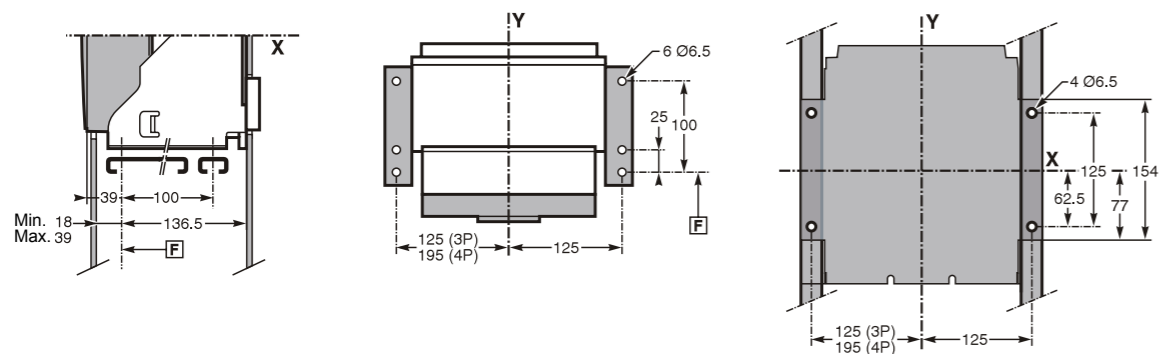

Safety clearance

Door open dimension

Back panel open dimension

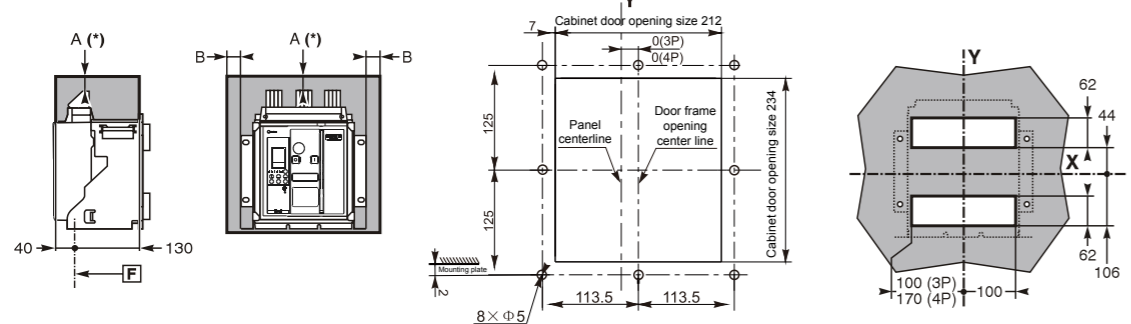

F : Datum point

	Insulation parts	Metal parts	Energized parts
A	0	0	100
B	0	0	60

Note: the X and Y axes of the 3-pole breaker are symmetrical with the breaker front face mask.
 (*) For the safety distance, the space required for removing the arcing mask shall be considered as 50mm, and the safety distance for removing the terminal block shall be 20mm.

Installation Dimension



Connection HDW3-1600M&S fixed type

Horizontal back connection

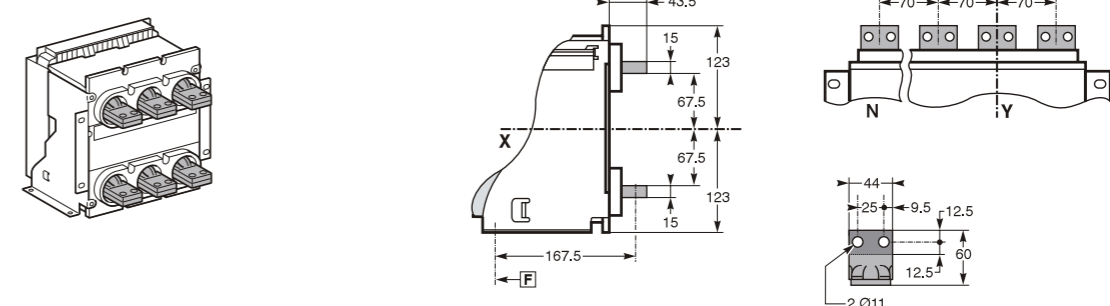

Vertical back connection

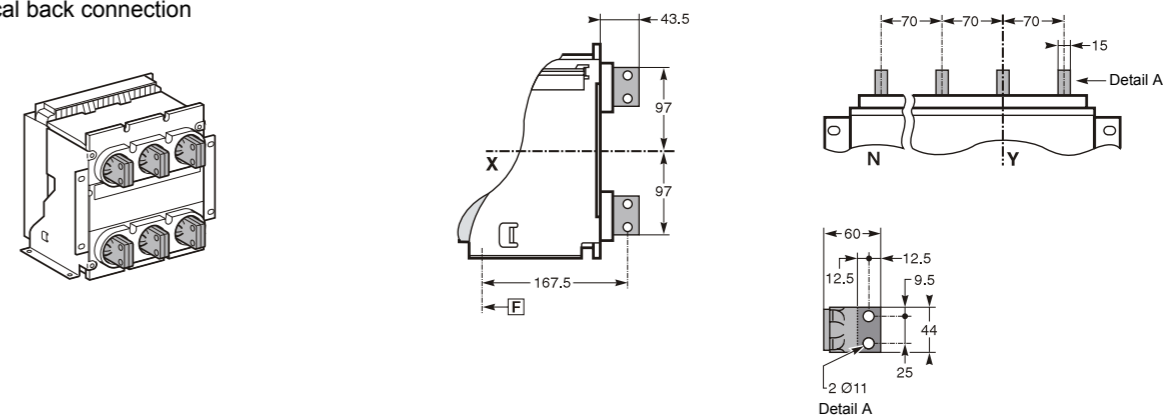

Back connection with expanding terminal

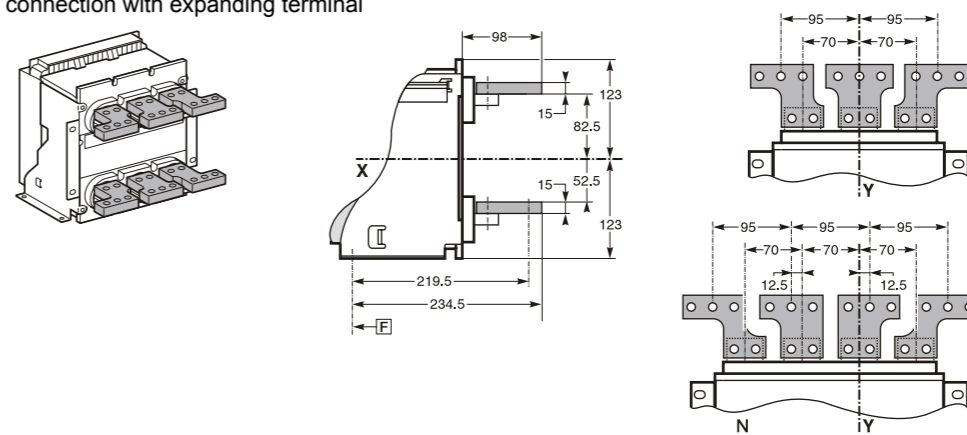

4-pole Left-center or right-center extension terminal

3-pole Intermediate extension terminal

4-pole Left or right extension terminal

3-pole Left or right extension terminal

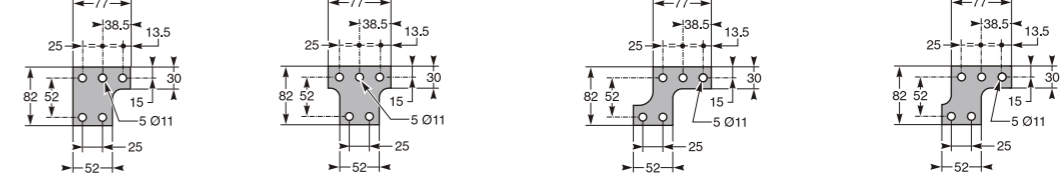

Note: The X and Y axes of the 3-pole breaker are symmetrical with the breaker nomenclature front face mask.

F : Datum point

Installation Dimension



Dimensions HDW3-1600 draw-out type 3P&4P

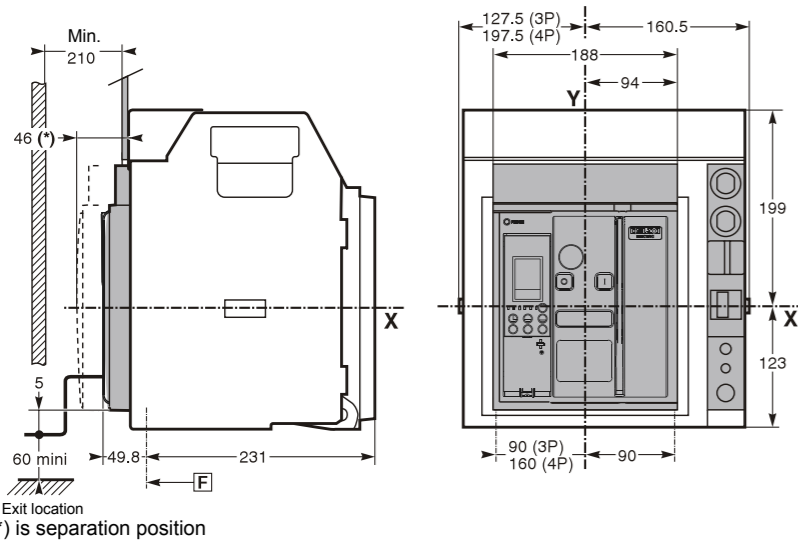

Horizontal Fixed (On a substrate or track)

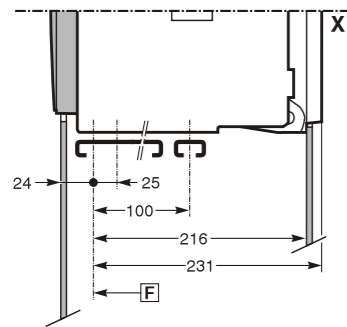

Vertical fixation diagram (On the back or rack)

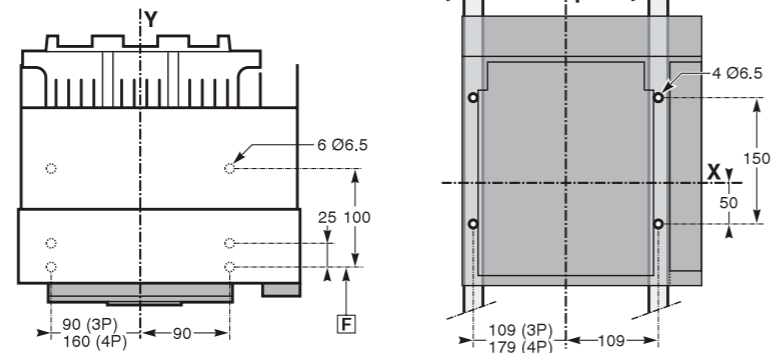

Safety clearance

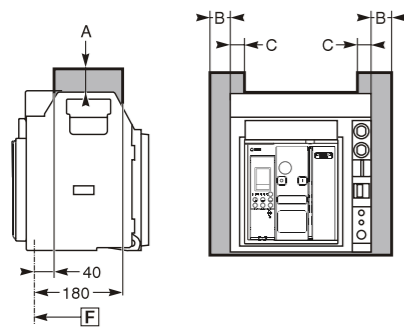

Door open dimension

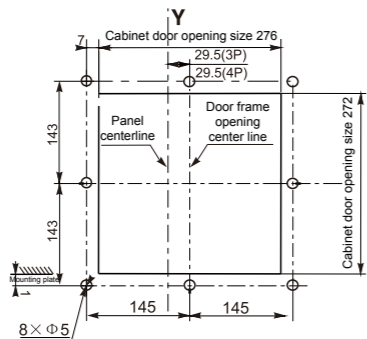

Back panel open dimension

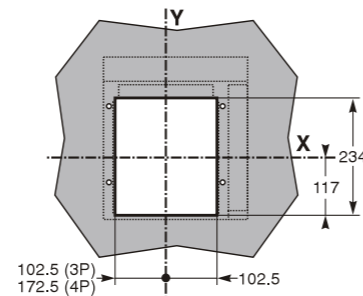

	Insulation parts	Metal parts	Energized parts
A	0	0	30
B	10	10	60
C	0	0	30

Note: The X and Y axes of the 3-pole breaker are symmetrical with the breaker nomenclature front face mask.

F : Datum point

Installation Dimension



Connection HDW3-1600M&S drawout type

Horizontal rear connection

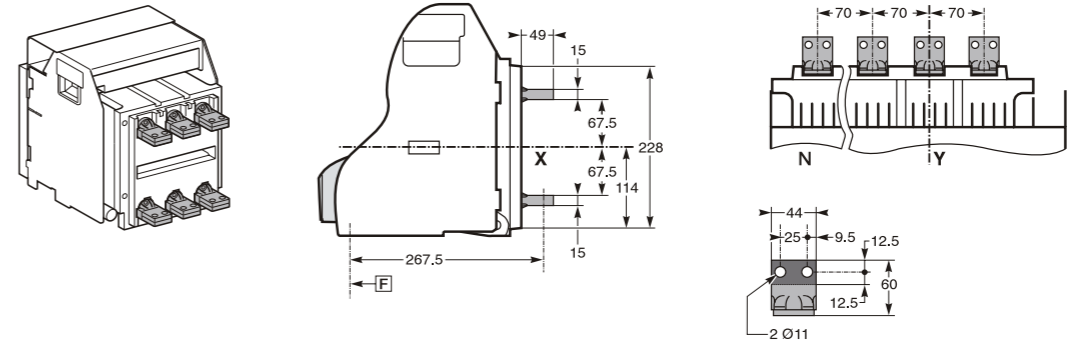

Vertical rear connection

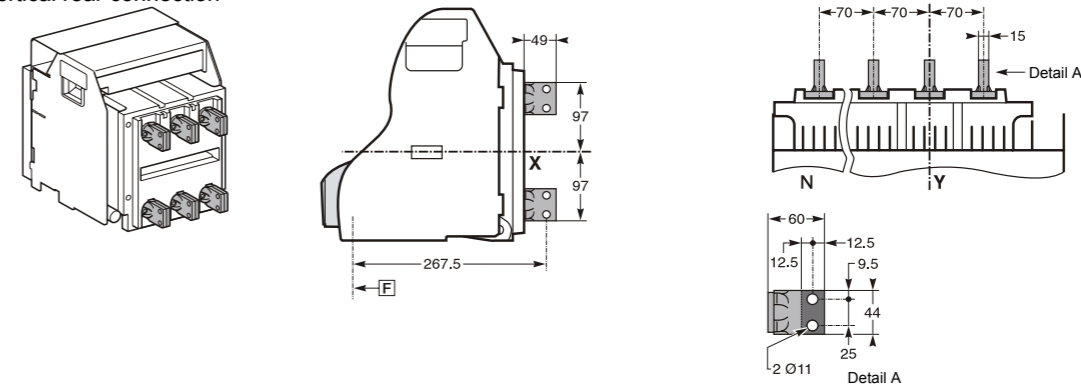

Rear connection with expanding terminal

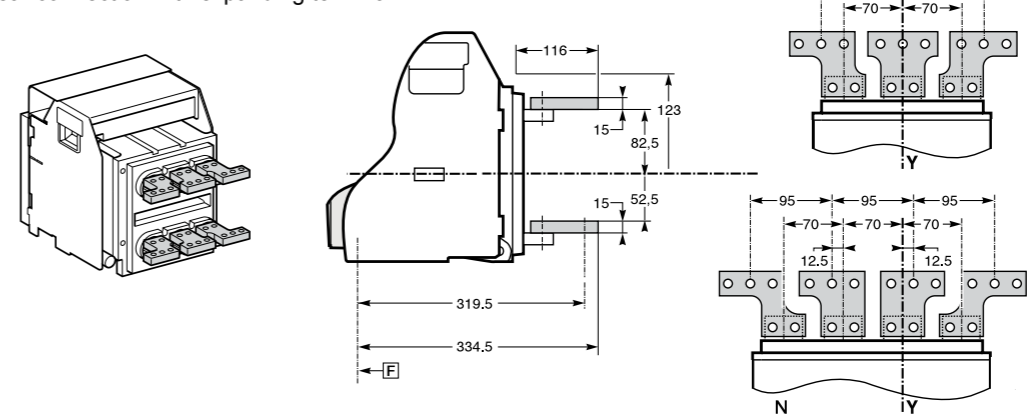

4-pole Left-center or right-center extension terminal

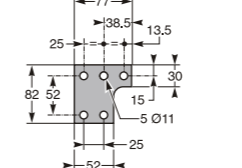

3-pole Intermediate extension terminal

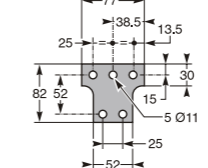

4-pole Left or right extension terminal

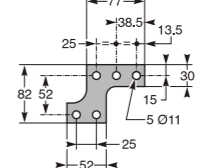

3-pole Left or right extension terminal

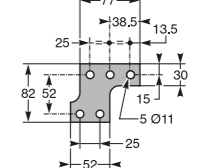

Note: The X and Y axes of the 3-pole breaker are symmetrical with the breaker nomenclature front face mask.

F : Datum point

Installation Dimension



Dimensions of HDW3-4000 fixed type 3P&4P

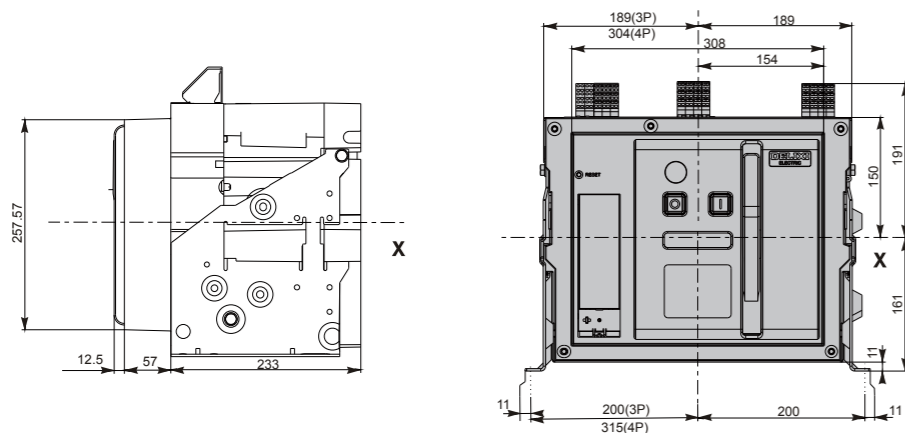

Horizontal Fixed (On a substrate or track)

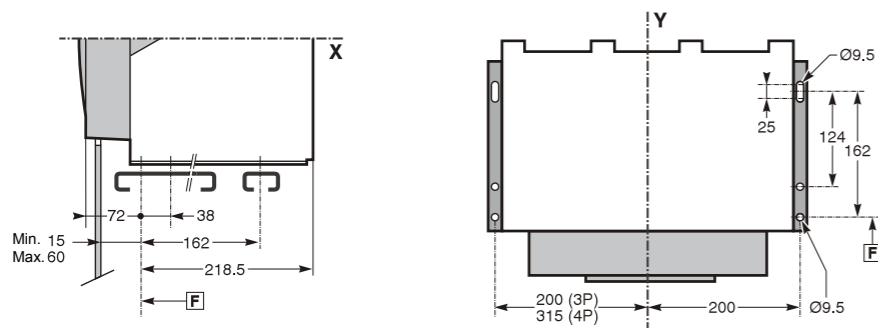

Safety clearance

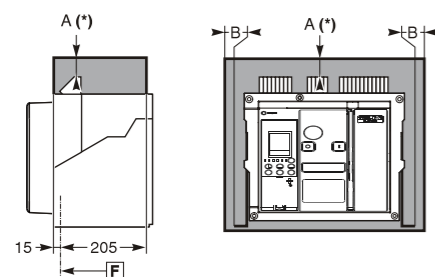

Door open dimension

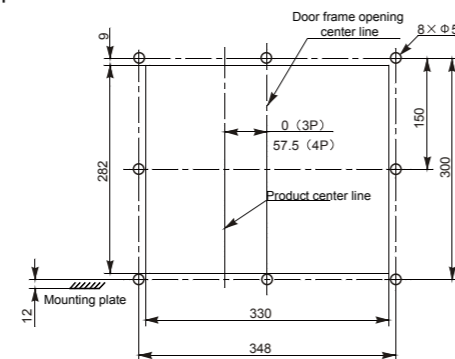

	Insulated part	Metal part	Live part
A	0	0	100
B	0	0	60

F: Datum point

Note: The X and Y axes of the 3-pole breaker are symmetrical with the breaker nomenclature front face mask.
 * The safe distance should consider the space needed to remove the arcing shield 110mm, the safe distance when removing the terminal block is 20mm

Installation Dimension



Connection HDW3-4000 fixed type 3P&4P 1600A~3200A

Horizontal rear connection

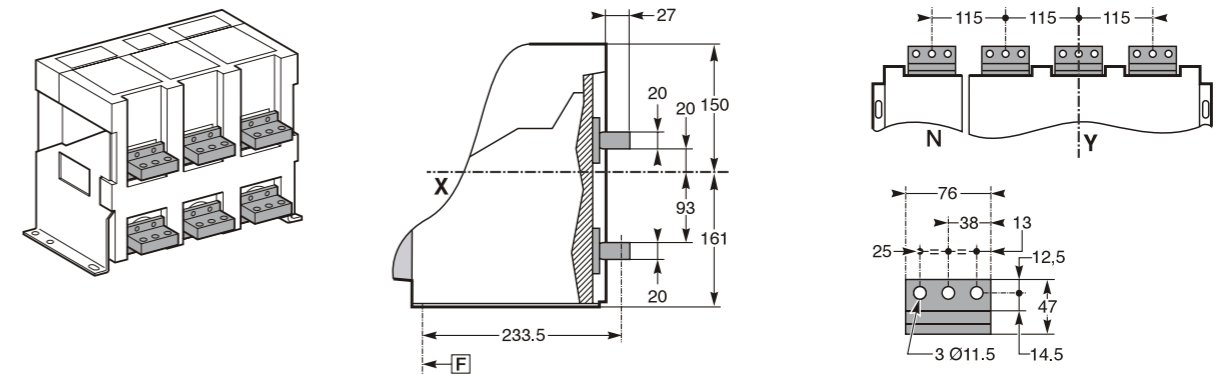

Vertical rear connection

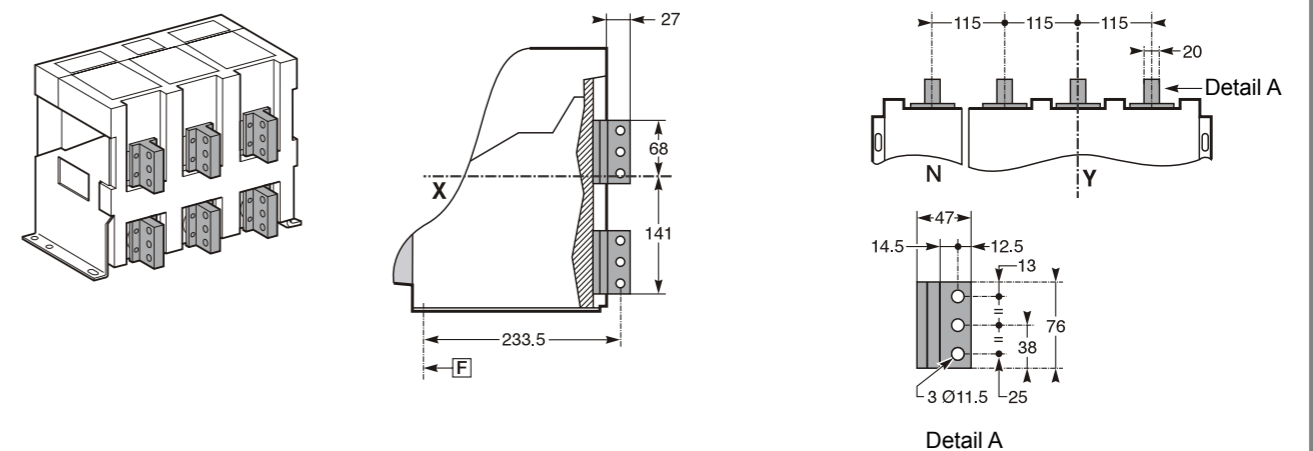

Installation Dimension



Connections HDW3-4000 fixed type 3P&4P 4000A

Horizontal rear connection

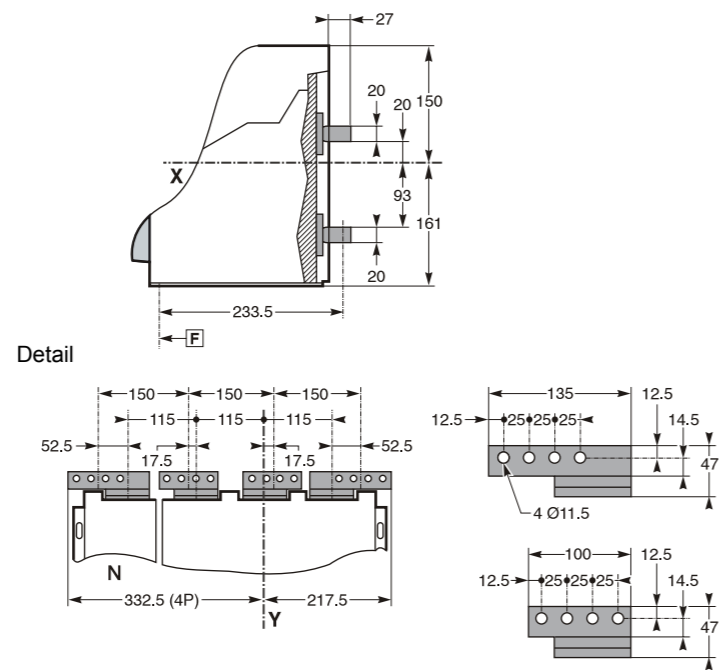
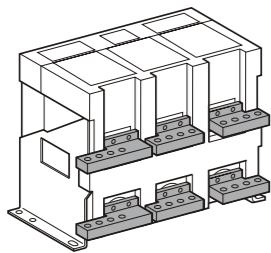

Vertical rear connection

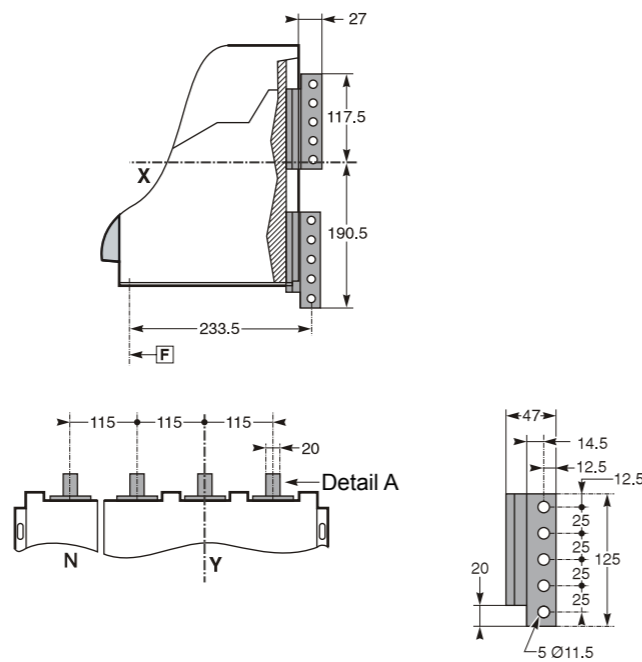
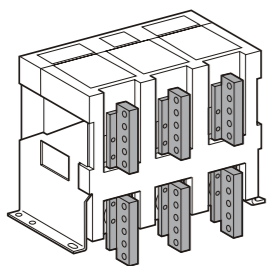

[F] : Datum point

Installation Dimension



Dimensions of HDW3-4000 draw-out type 3P&4P

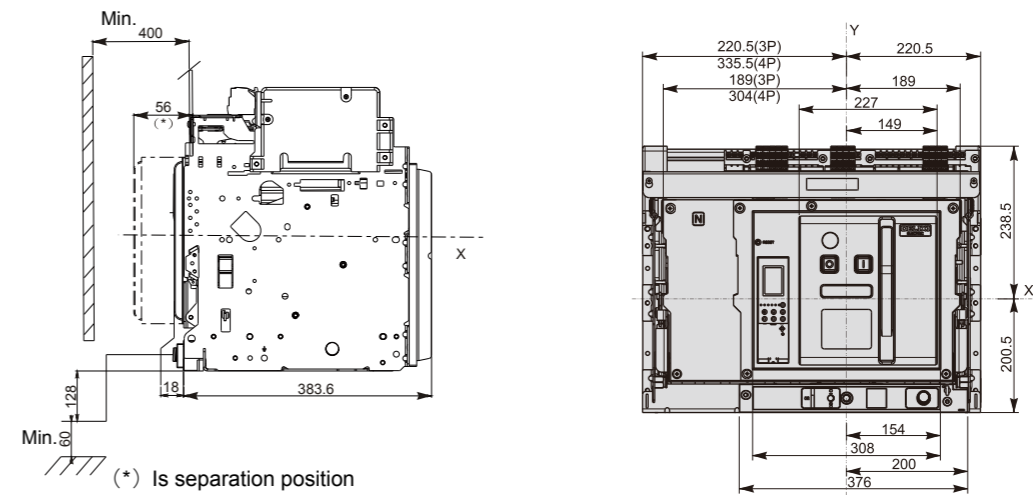

Horizontal Fixed (On a substrate or track)

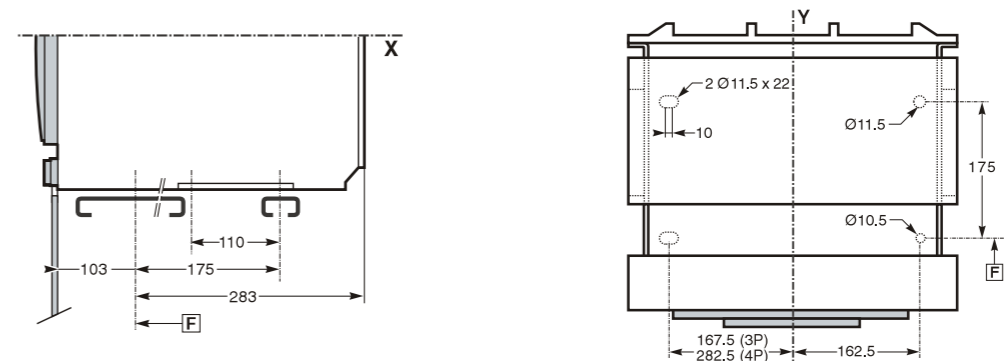

Safety clearance

Door open dimension

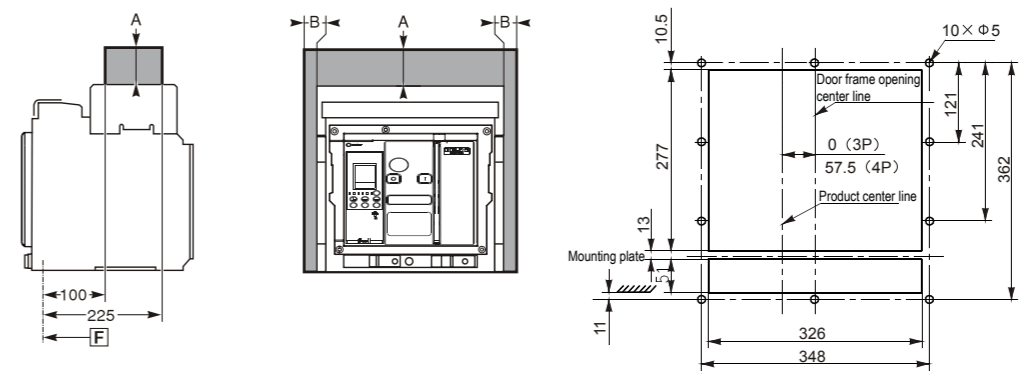

	Insulated part	Metal part	Live part
A	0	0	0
B	0	0	60

[F] : Datum point

* Note: The X and Y axes of the 3-pole breaker are symmetrical with the breaker nomenclon front face mask. The safe distance should consider the space needed to remove the arcing shield

Installation Dimension



Connections HDW3-4000 draw-out type 3P&4P 1600A~3200A

Horizontal rear connection

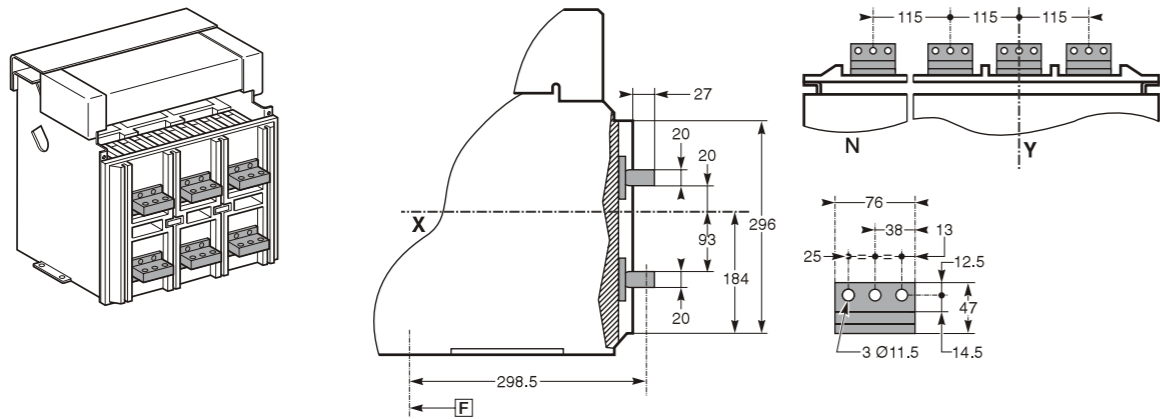

Vertical rear connection

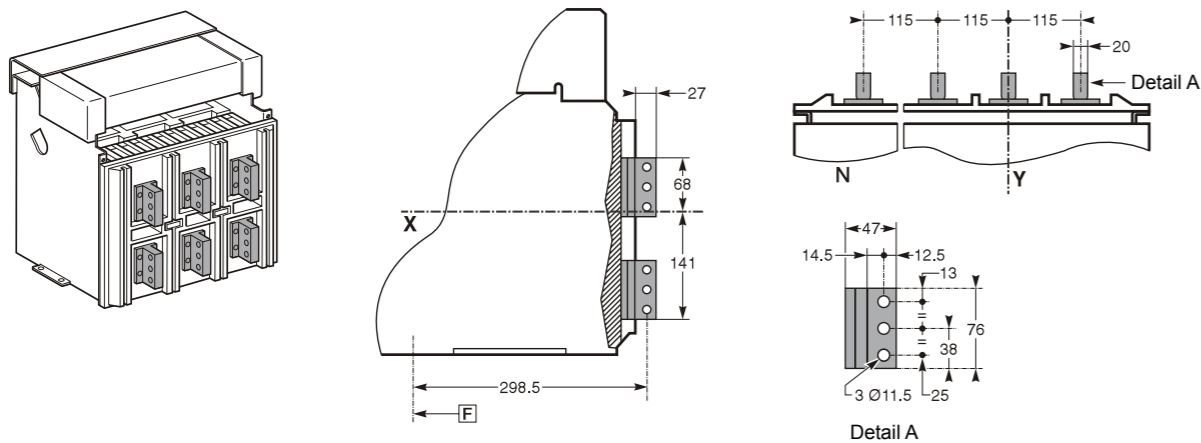

Installation Dimension



Connections HDW3-4000 draw-out type 3P&4P 4000A

Horizontal rear connection

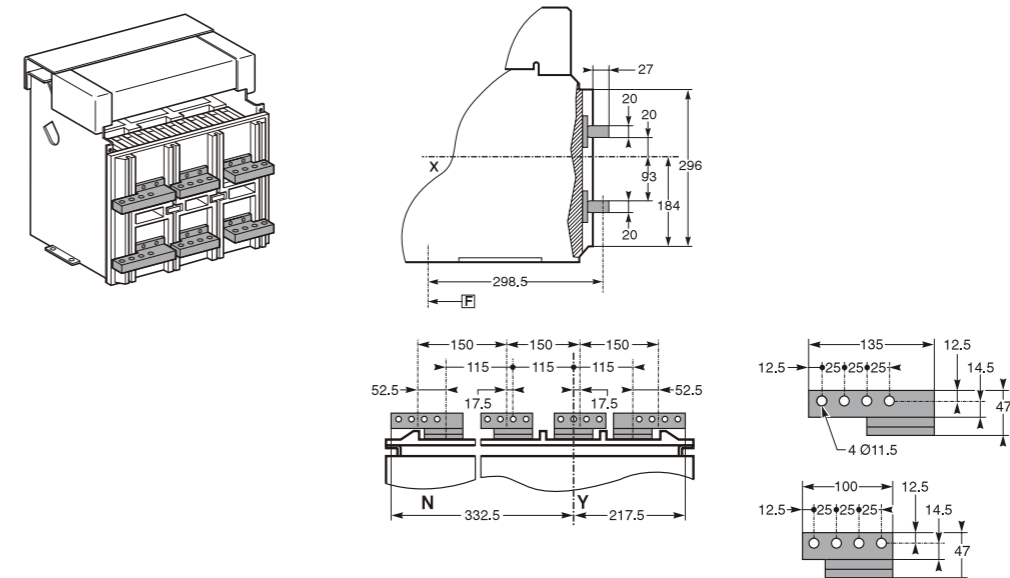

Vertical rear connection

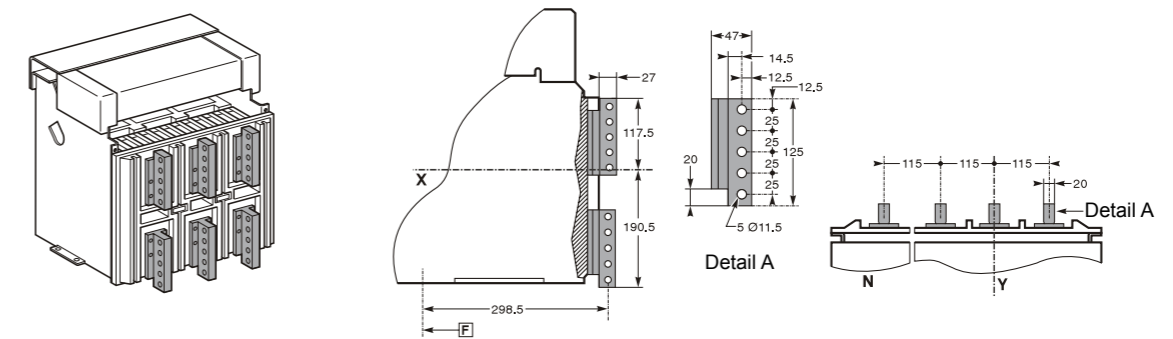

F: Datum point

It is suggested to connect the circuit breaker with guide line

Rated current A	Specification of external copper platoon	Pole number	Sectional areamm ²
400	None	1	240
630	40×5	2	400
800	50×5	2	500
1000	60×5	2	600
1250	80×5	2	800
1600	100×5	2	1000
2000	100×5	3	1500
2500	100×5	4	2000
3200	120×10	3	3600
4000	100×10	5	5000

Detailed information please refer to the specification

Installation Dimension



Connections HDW3-6300M&S

6300M&S Draw-out type 3P&4P Dimension **F** Datum Point

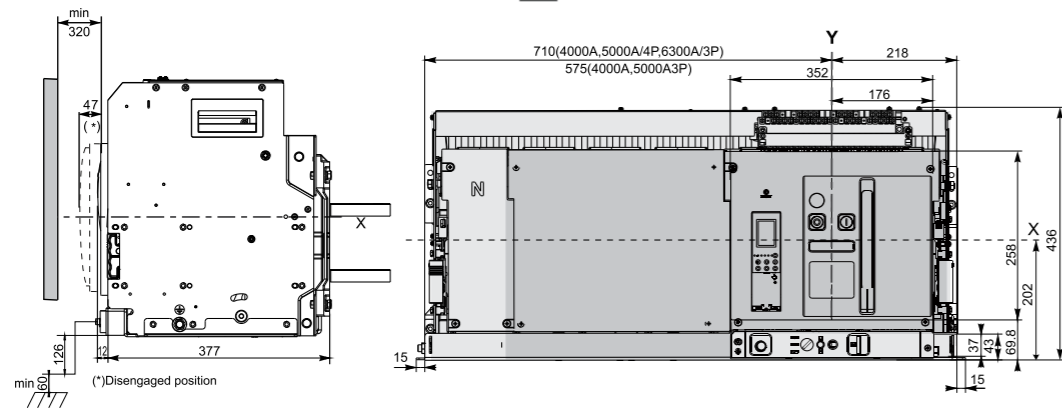

Horizontal installation *Cover is 5mm beyond door frame.

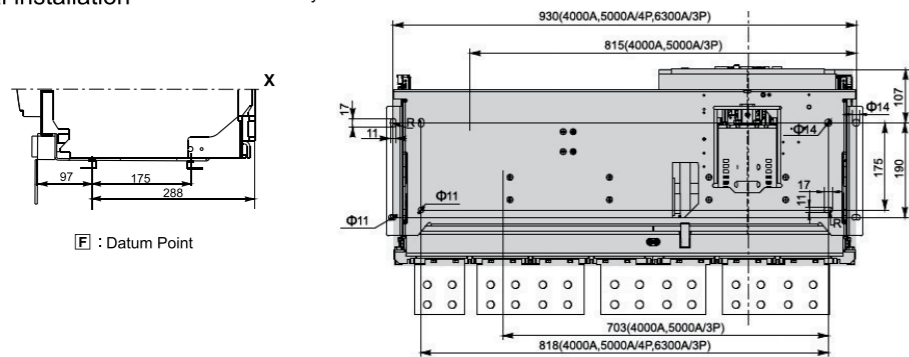

Safety clearance

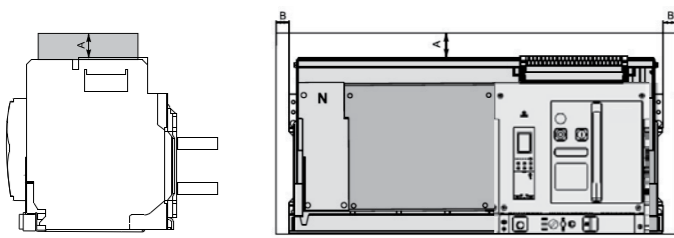

Safety clearance (mm)	Draw-out type	
	A	B
Non-conductor	0	0
Metals	0	0
Energized conductor	100	60

Holes size on door

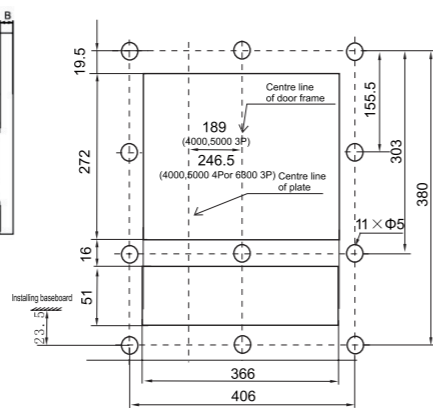

Installation Dimension



Connections HDW3-6300M&S

6300M&S Draw-out type connection **F** Datum Point

4000A-6300A
Horizontal connection

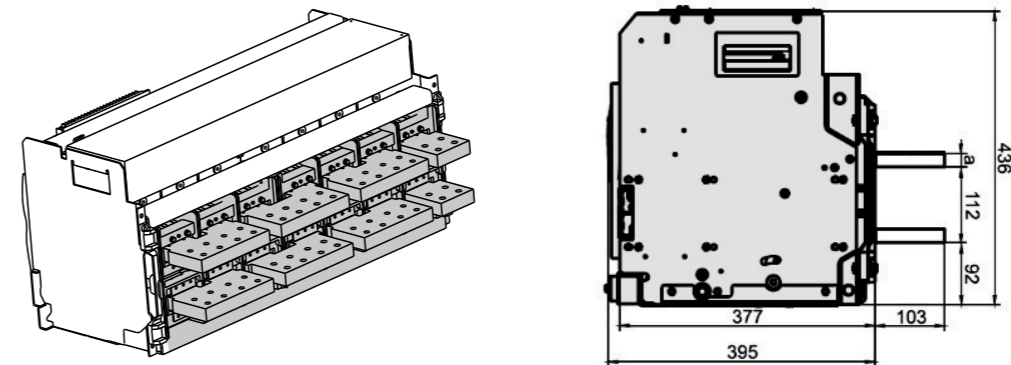

In=4000A/5000A

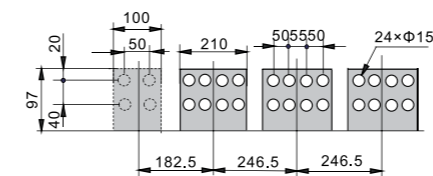

In=6300A

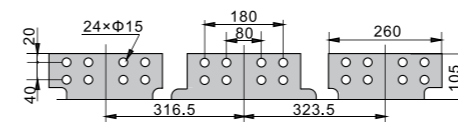

In (A)	a (mm)
4000	20
5000	30
6300	30

Installation Dimension



Dimensions of external transformer

N-phase extend current transformer

1) 1600M&S

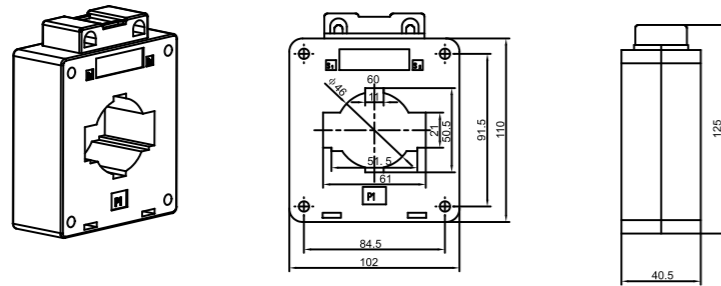

2) 2000M&S

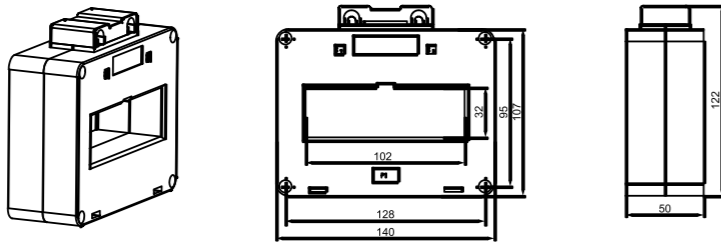

3) 3200M&S

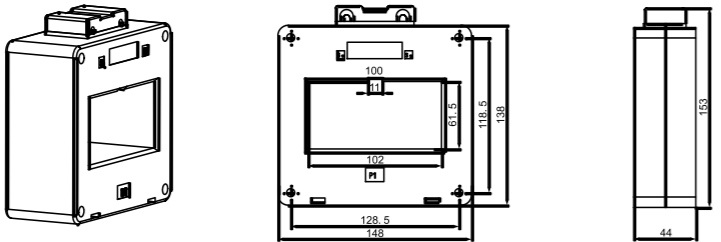

4) 4000M&S

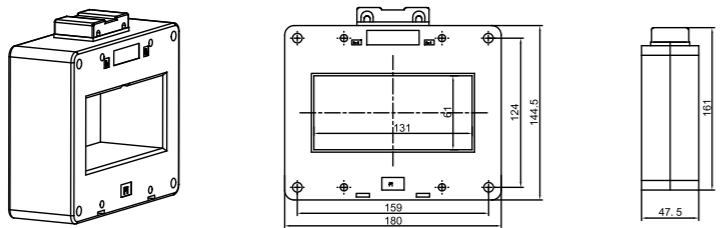

5) 6300M&S

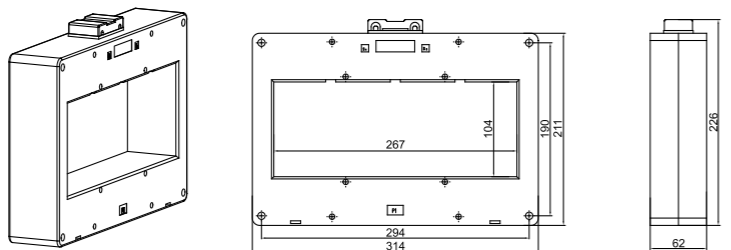

Installation Dimension



Dimensions of external transformer

Earth-leakage current transformer

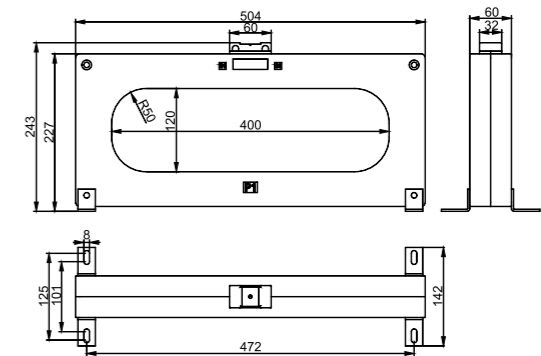
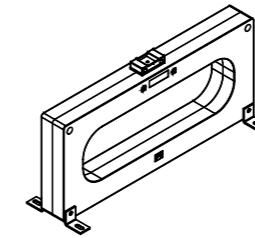

Ground return current transformer

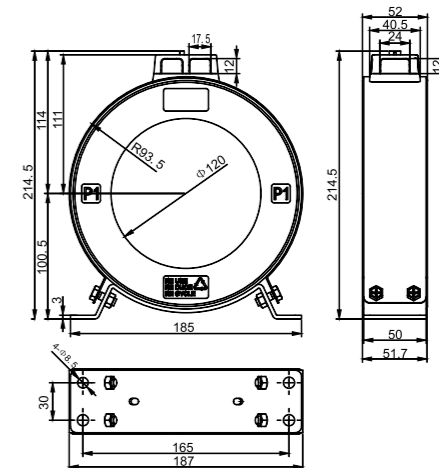
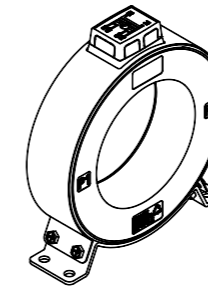

Remark: Dimension of 4000A, 5000A, 6000A is the same with earth-leakage current transformer

Power supply module

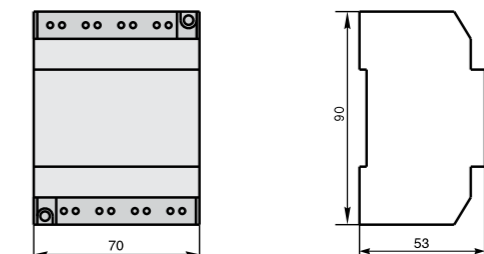
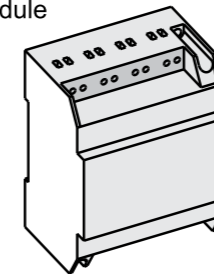

Signal convert module

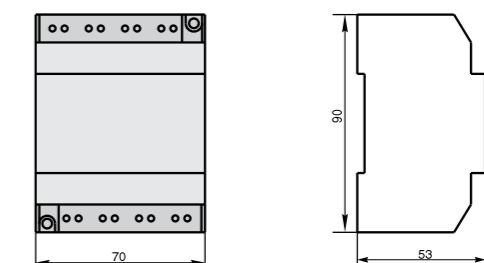
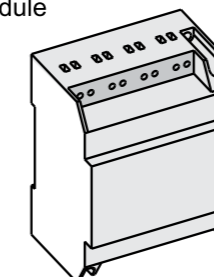

Electrical Schematic Diagram



iTR326、iTR326A Electrical schematic diagram

Wiring diagrams of iTR326, iTR326A intelligent controllers

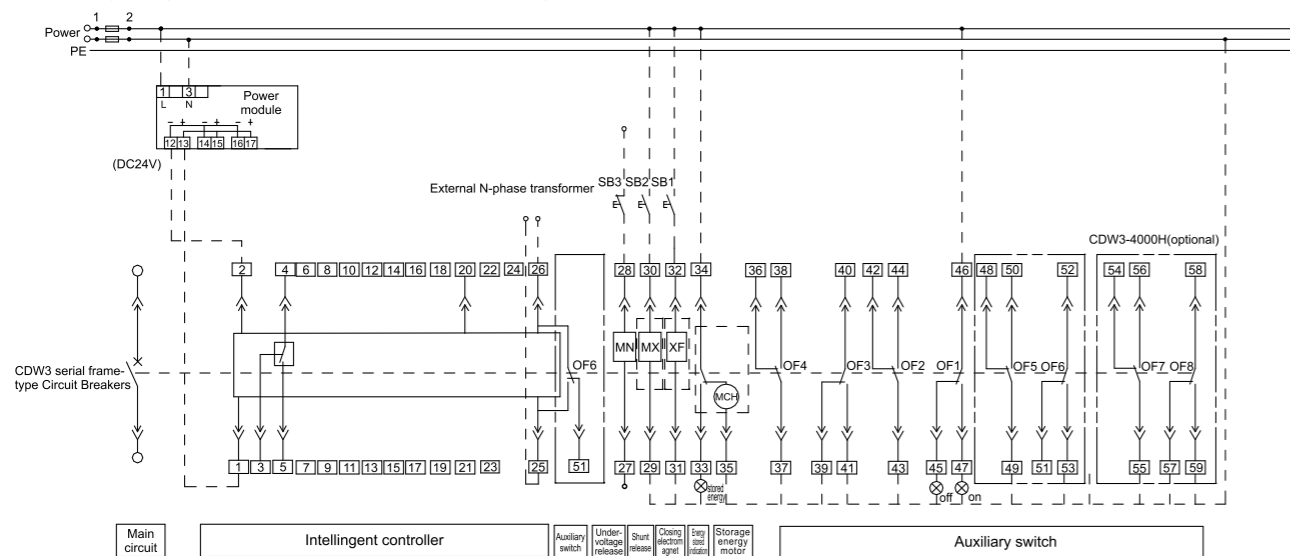

Controller wiring annotations

- UM: Voltage test signal input
- 21#(UN), 22#(UA), 23#(UB), 24#(UC) represent the input ends of N, A, B, C phase voltage respectively.
- POW: External power input
- 1#(V1+), 2#(V2-): Auxiliary power input/output terminals, 1#(V1) is the positive terminal for DC
- SWT: Fault trip contact output
- 3#(S2), 4#(S1), 5#(S3): Fault trip contact output (4#(S1) is the common terminal), contact capacity: AC400V, 5A
- CT: External transformer, including external N-phase transformer or ZT100 or ZCT1(one out of three), where
- 25# - 26#: apply to external N-phase transformer input;
- 25# - 26#: apply to external ground transformer ZT100 input;
- 25# - 26#: apply to external leakage transformer ZCT1 input;
- Note 1: MN under-voltage release 27#, 28# wired on the main circuit line
- Note 2: Different powers can be applied respectively if the control power voltages for MN, MX, XF, MCH are different from each other, HDW3-1600 auxiliary switch offer 4a4b only; HDW3-2000&HDW3-3200 auxiliary switches can offer 4a4b and 6a6b; HDW3-4000 auxiliary switch can offer 4a4b, 6a6b and 8a8b, where 4a4b is a standard configuration, others need to be purchased separately (the dashed parts in the diagram are connected by the users);
- Note 3: Terminal 35# not only can be connected directly to the power (pre-store energy automatically), but also can be connected with the NO button in series then connected to the power (hand control energy pre-storage)
- Note 4: The controller should be connected to the power module, adopt iAPU334 power module when the power voltage is AC220V-AC400V; adopt iAPU332D when the power voltage is DC220/DC110V;
- Note 5: The auxiliary switch is 4a4b when HDW3-2000 and HDW3-2000 are circuit 47;
- Note 6: The auxiliary switch is 6a6b (5a5b) when HDW3-2000 and HDW3-3200 are circuit 51: 25#, 26#, 51# can not take the external transformer after forming a NO NC contact.

- Elements:
- MN Under-voltage release
 - MX Shunt release
 - XF Closed electromagnet
 - OF1-OF8 auxiliary switch
 - SB1 closing button
 - SB2 opening button
 - SB3 emergent disconnect button

Equal No.
27=D2
28=D1
29=C2
30=C1
31=A2
32=A1
33=B3
34=B1
35=B2

Electrical Schematic Diagram



iTR326H Electrical schematic diagram

Wiring diagrams of iTR326H intelligent controllers

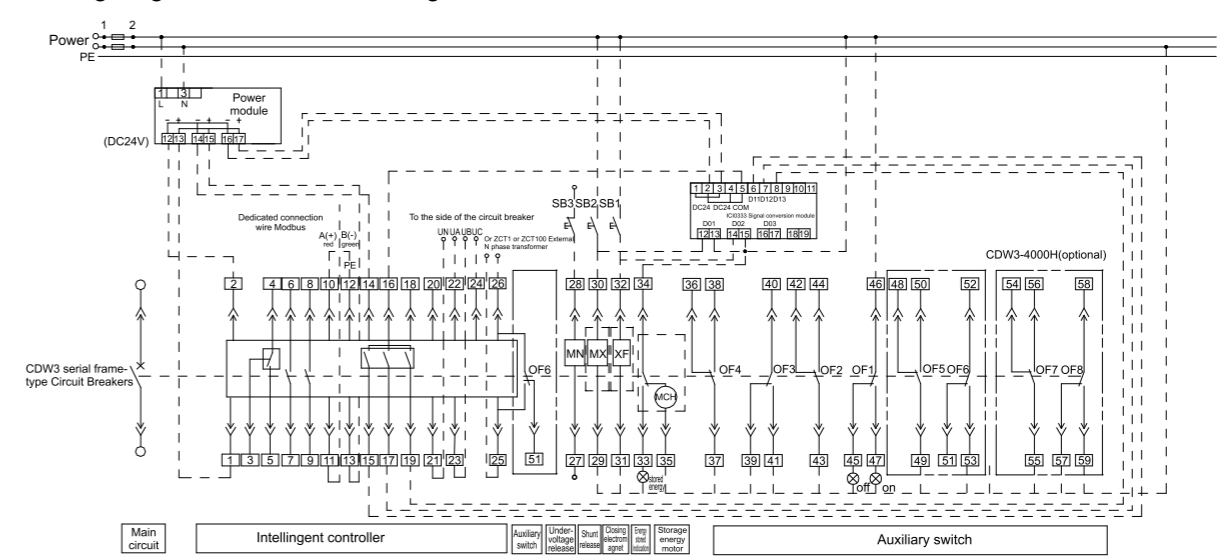

Controller wiring annotations:

- UM: Voltage test signal input
- 21#(UN), 22#(UA), 23#(UB), 24#(UC) represent the input ends of N, A, B, C phase voltage respectively.
- ZSI: Zone selective interlock
- 13#(Z+), 14#(Z-) are the zone selective interlock input DC24V
- 16#(Z1), 15#(Z1), 17#(Z2), 19#(Z3) are 3D0 output, adopt the optocoupler output, where 16# (Z1) is the common terminal
- POW: External power input
- 1#(V1+), (2# V2-): Auxiliary power input/output terminals, 1#(V1+) is the positive pole for DC.
- SWT: Fault trip contact output
- 3#(S2), 4#(S1), 5#(S3): Fault trip contact output (4#(S1) is the common terminal), contact capacity: AC400V, 5A
- COM: Communication output
- 10#, 11#: Communication outgoing lines of RS485A(485+), RS485B(485-) respectively, 12#: PE line, shield ground wire
- CT: External transformer, including an external N-phase transformer or ZT100 or ZCT1(one out of three), where
- 25# - 26#: Apply to external N-phase transformer input;
- 25# - 26#: Apply to external ground transformer ZT100 input;
- 25# - 26#: Apply to external leakage transformer ZCT1 input;
- Note 1: MN under-voltage release 27#, 28#, wired on the main circuit line
- Note 2: Different powers can be applied respectively if the control power voltages for MN, MX, XF, MCH are different from each other, HDW3-1600 auxiliary switch offer 4a4b only; HDW3-2000 and HDW3-3200 auxiliary switches can offer 4a4b and 6a6b; HDW3-4000 auxiliary switch can offer 4a4b, 6a6b and 8a8b, where 4a4b is a standard configuration, others need to be purchased separately (the dashed parts in the diagram are connected by the users);
- Note 3: Terminal 35# not only can be connected directly to the power (pre-store energy automatically), but also can be connected with the NO button in series then connected to the power (hand control energy pre-storing)
- Note 4: The controller should be connected to the power module, adopt iAPU334 power module when the power voltage is AC220V-AC400V; adopt iAPU332D when the power voltage is DC220/DC110V;
- Note 5: The auxiliary switch is 4a4b when HDW3-2000 and HDW3-3200 are circuit 47;
- Note 6: 25#, 26# are the external transformer input terminals, used for ground fault protection (3P+N)T; The auxiliary switch is 6a6b (5a5b) when HDW3-2000 and HDW3-3200 are circuit 51: 25#, 26#, 51# can not take the external transformer after forming a NO NC contact.
- Note 7: When the remote control is working, the signal conversion modules are needed, signal conversion module contact capacity is AC240V, 10A
- Note 8: The communication protocol is Modbus, iCAU486 or iCAU485 is needed to be ordered when Profibus or Devicenet protocol is used, the module uses DC24V electricity supply, the input end is connected to the secondary circuit 10#(485+), terminal 11#(485-), the output end is connected to the corresponding protocol bus.

- Elements:
- MN Under-voltage release
 - XF Closed electromagnet
 - OF1-OF8 Auxiliary switch
 - ZT100 Ground transformer
 - SB1 Closing button
 - SB2 Opening button
 - SB3 Emergent disconnect button
 - MX Shunt release
 - MCH Motor
 - ZCT1 Leakage transformer

Equal No.
27=D2
28=D1
29=C2
30=C1
31=A2
32=A1
33=B3
34=B1
35=B2

Tripping Curve



Tripping Curve

3 phases protection

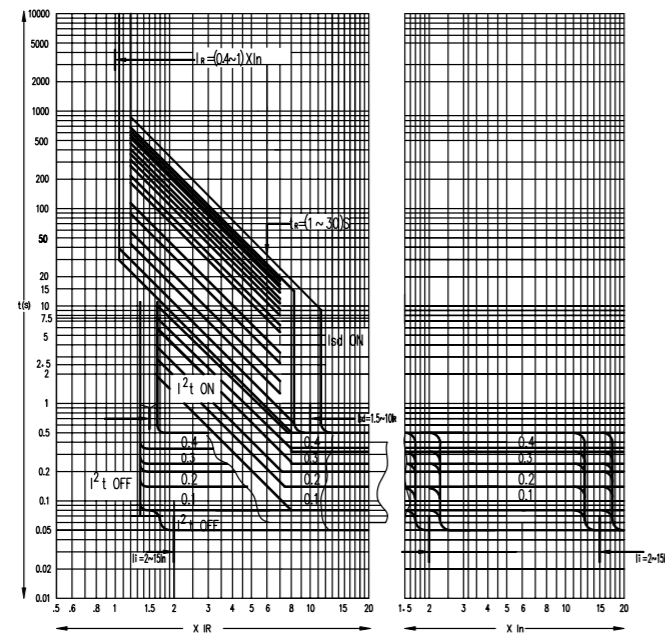

Ground protection

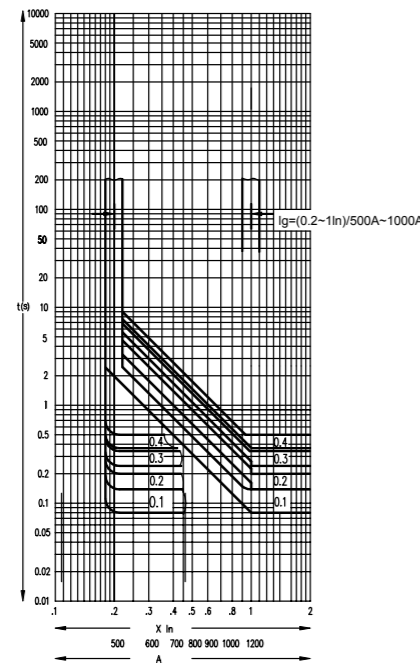

Ground Fault Protection



Ground Fault Protection

For definite earth-fault protection the setting current I_g can be adjusted $0.4-1 I_n$, can be setted "OFF", Delay time can be adjusted t_g $0.1-0.4$.

Protection ways Inverse timedelay protection and constant time delay protection is available.

Vectorial summation type

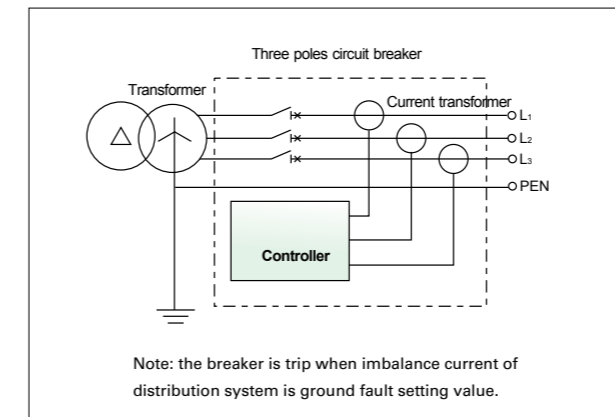

HDW3 with three poles are used in the power distribution system of TN-C, TN-C-S and TN-S without additional current transformer of neutral line N. The signal of earth-fault protection from the vectorial summation of three poles of current.

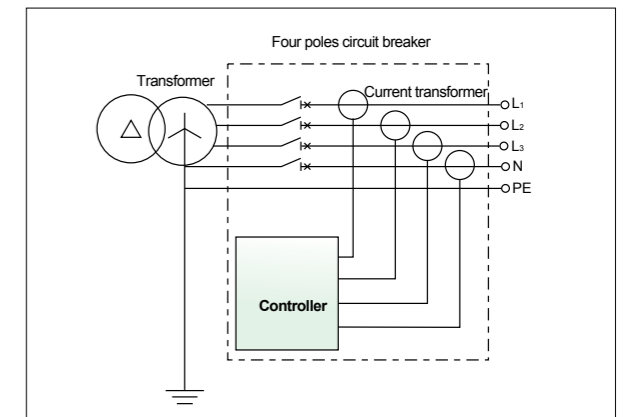

HDW3 with four poles are used in the power distribution system of TN-S. The signal of earth-fault protection from the vectorial summation of three poles of current and N phase current.

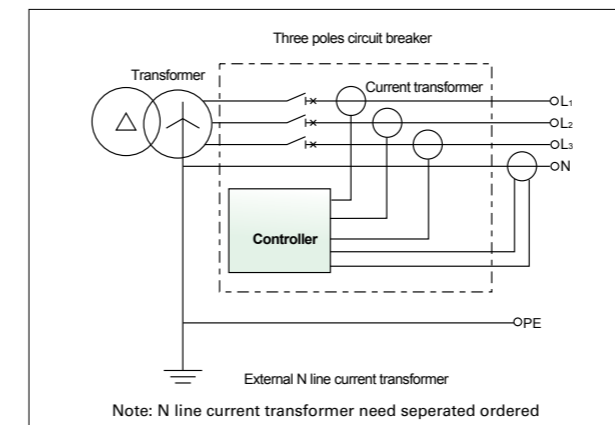

HDW3 with three poles are used in the power distribution system of TN-S. N line current transformer connected externally, which is installed 2meters at maximum from the circuit breaker, takes the hole of earth-fault protection. The signal of earth-fault protection from the vectorial summation of three poles of current and N phase current.

Earth type of transformer center

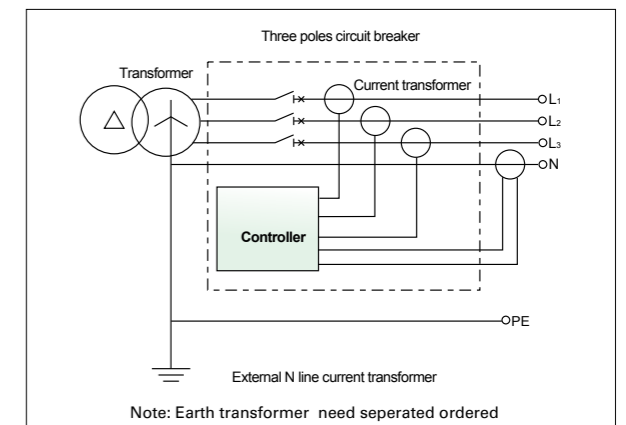

TN-S distribution system selects transformer's center earth type protection. Earth transformer with transformer's center takes the hole of sampling earth-fault current. Earth-fault protection signal is from earth line of transformer.



Product Introduction

HDW3 automatic transfer controller is an intelligent ATSE controller with programmable functions, automatic measuring, LCD menu display, and digital communication. It can automatically realize voltage, frequency, phase etc. electrical parameters measurement and automatic control according to setting strategy which can reduce human operation error. It is an ideal product of ATSE.

HDW3 automatic transfer controller consists of microprocessor as core. 3-phase voltage and make precise recognition about abnormal voltage (over-voltage, under-voltage, missing phase, over-frequency, under-frequency) . This device considers fully the application with compact structure, advanced circuit, simple wiring, highly reliable, it can be widely applied to electrical devices, automatic control and debug system in industry of power, post and telecommunications, petroleum, coal, metallurgical, railway, mu

ATSEC2

Two-source AC power input
Main power source and standby power source



ATSECM

Two-source AC power input
Two Main power source and tie bus interlock



ATSEC3

Three-source AC power input
Main power source and two standby power source



Main function of ATS controller

ATSEC2

Two-source AC power input
Main power source and standby power source

functional parameter

- Graphic LCD 128x64 pixel;
- Two-source AC power input: 3-phase 4-wire;
- Measured values, settings, and message texts are supported in English and Chinese
- 10~30VDC power supply.
- Detection function for over-voltage, under-voltage, phase loss, reverse phase sequence, over-frequency, under-frequency;
- 8-channel programmable digital input (grounding effective);
- 10-channel programmable digital output;
- Integrated RS-485 isolation interface, MODBUS protocol;
- Storage of last 200 events;
- Real time clock
- All parameters are field programmable, use password access to avoid misoperation by unprofessional persons;
- The fixed washer is IP65 degree of protection
- Module structure design, Retardant PC cover, pluggable terminal, embedded installation mode, compact structure and easy installation;

Main function of ATS controller

ATSECM

Two-source AC power input
Two Main power source and tie bus interlock

functional parameter

- Graphic LCD 128x64 pixel, 5 inch TFT;
- Two-source AC power input: 3-phase 4-wire; (Three -source AC power input-ATSEC3)
- Measured values, settings, and message texts are supported in English and Chinese;
- 12~48VDC power supply;
- Detection function for over-voltage, under-voltage, phase loss, reverse phase sequence, over-frequency, under-frequency;
- 8-channel programmable digital input (grounding effective);
- 10-channel programmable digital output;
- Integrated RS-485 isolation interface, MODBUS protocol;
- Storage of last 200 events;
- Real time clock;
- All parameters are field programmable, use password access to avoid misoperation by unprofessional persons;
- The fixed washer is IP65 degree of protection;
- Module structure design, Retardant PC cover, pluggable terminal, embedded installation mode, compact structure and easy installation;

ATSEC3

Three-source AC power input
Main power source and two standby power source



Parameter	Definition	Default	ATSE2C	ATSECM	ATSE3C
Basic Parameter					
operation temperature	-20 +70		■	■	■
storage temperature	-30 +85		■	■	■
Humidity	20% 90%		■	■	■
Altitude	≤2000m		■	■	■
Breaker Operation voltage(V)	AC 230/415V	AC 230V	■	■	■
ATS Operation voltage(V)	AC 230V/415V DC10-30V		■	■	■
IP degree	IP20		■	■	■
Display	LCD , English ,Chinese	English	■	■	■
Parameter Setting					
Power source voltage	AC 50-415V		■	■	■
Power source frequency	50 Hz/60 Hz	50 Hz	■	■	■
Power grid	3 Pole 4 wires / 3 Pole 3 wires	3P4W	■	■	■
ATSE2C/ATSECM power transfer type	M-M:Mains to Mains Supply M-G:Mains to Generator Supply G-M:Generator to Mains Supply	M-M	■	■	
ATSE3C power transfer type	M-M:Mains to Mains Supply to Mains Supply M-M:Mains to Mains Supply to Generator Supply	M-M			■
RETURNS					
RETURNS model	Self return/No return/Backup eachother	Self return	■	■	■
Power grid	Choose S1 or S2 for Priority Net	S1	■		
Transfer Parameter					
Loss phase/loss voltage	Main & standby power supply		■	■	■
Under voltage	70%-98%	85%	■	■	■
Over voltage	102% -130%	115%	■	■	■
Under frequency	OFF/80%-98%	OFF	■	■	■
Over frequency	OFF/101%-119%	OFF	■	■	■
Phase unbalance	Main & standby power supply		■	■	■
Fire signal	Fire signal D/O switch off all breaker		■	■	■
Manu/Auto	Manu model/Auto model		■	■	■
Dual switch off button	push dual switch off button,switch off all breaker		■		
alarm for transfer failure	panel LED light +sound alarm		■	■	■
Communicate & event log					
Event log	Transfer and alarm event		■	■	■
Communication	RS-485 MODBUS		■	■	■
Dry contact output					
Main power's breaker switch on	10A 250VAC		■	■	■
standby power's breaker switch on			■	■	■
Main power status			■	■	■
standby power status			■	■	■
generator start			■	■	■
Control cable	ATSE2C default with 2m ATSE3C ATSECM default with 4m		■	■	■



How to order complete set of ATS with ACB

The complete set must including 2 or 3 set ACB cable interlock ,220VAC motor/shunt release /closing coil,ATS Controller
Do not install key lock with ACB, it will damaged the ACB when automatic transfer
Do not install the undervoltage release with ACB, It will impact ATS automatic transfer
Do not use ACB's MODBUS or remote signal to Switch ON/OFF breaker by MX/XF, It will impact the ATS automatic transfer

Cable Interlocking

Two Breaker Interlock C2

Interlock type A in which one of the two breakers (B1 or B2)can be switched ON. Each breaker must be equipped with a factory mounted interlock type A. Two cables are needed.

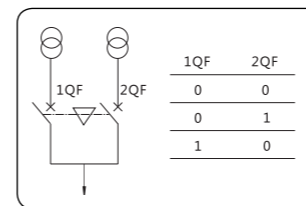

Three Breaker Interlock C3

Interlock type B in which one of the three breakers (B1, B2 or B3) can be switched ON. Each breaker must be equipped with a factory mounted interlock type B. Six cables are needed.

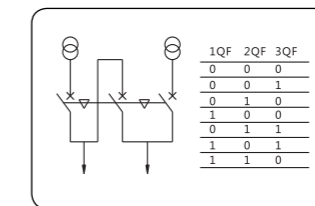

Three Breaker Interlock type CM

Interlock type A in which one of the two breakers (B1 or B2)can be switched ON. Each breaker must be equipped with a factory mounted interlock type A. Two cables are needed.

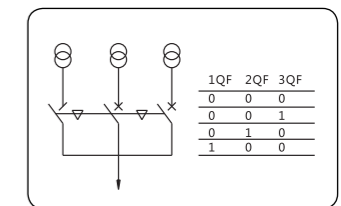

ATS controller + ACB + Mechanical interlock

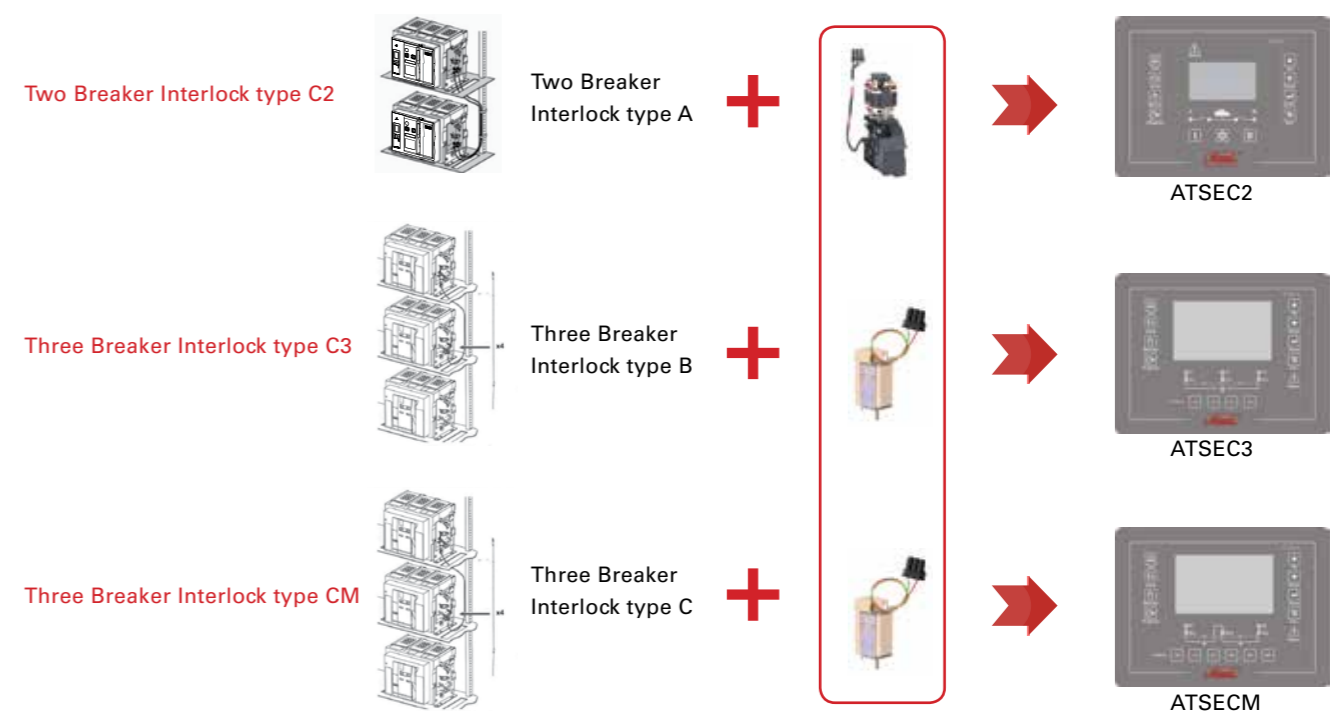



ATS controller-Wiring diagram -ATSEC2

Terminal diagram

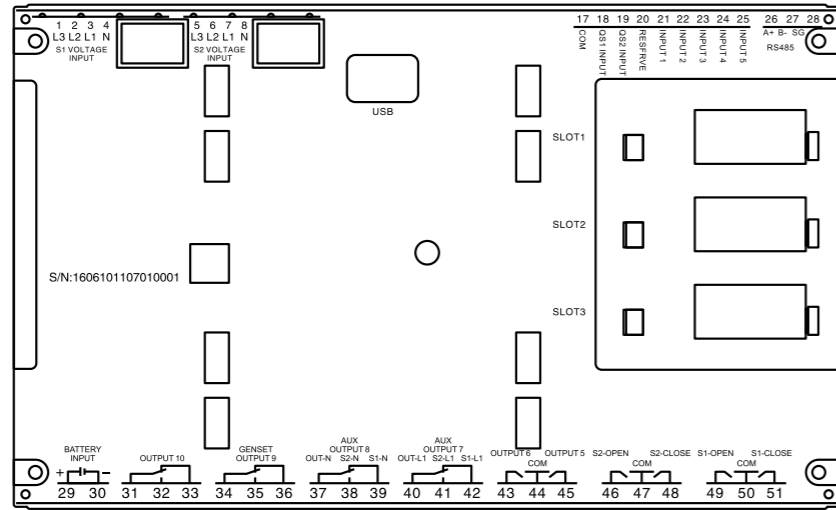

Installation Dimension

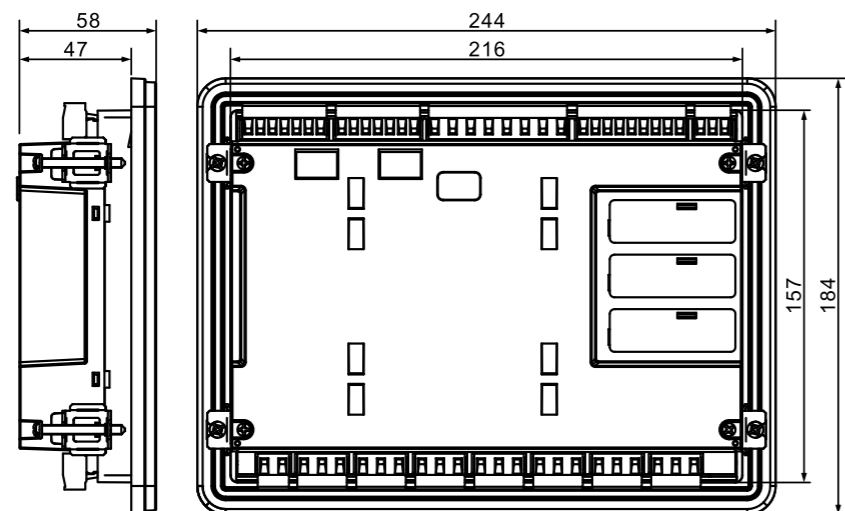

ATS controller-Wiring diagram -ATSEC2

Electrical Schematic Diagram

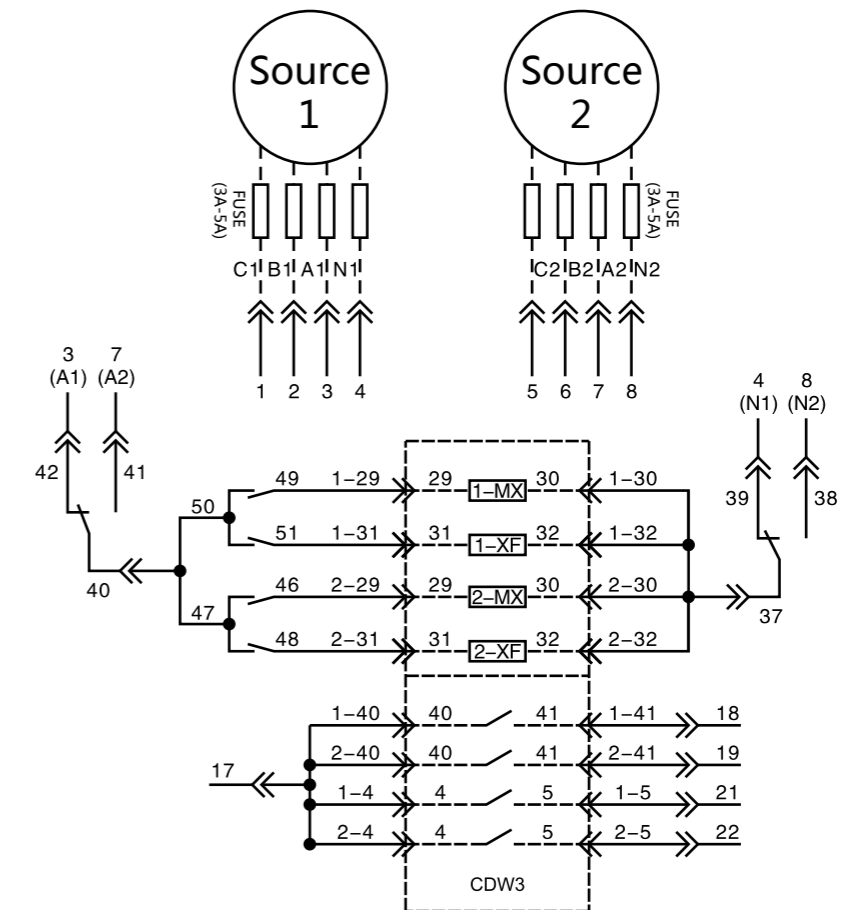

- | | | | | | |
|----------------|----|-------|----|-----------|--------------------------------------|
| Gen set common | 34 | Start | 35 | 1 - MX | Source 1 breaker - shunt release |
| | | Stop | 36 | 1 - XF | Source 1 breaker - closing coil |
| | | | | 2 - MX | Source 2 breaker - shunt release |
| | | | | 2 - XF | Source 2 breaker - closing coil |
| | | | | 1-40 1-41 | Source 1 breaker - Auxiliary contact |
| | | | | 2-40 2-41 | Source 2 breaker - Auxiliary contact |
| | | | | 1-4 1-5 | Source 1 breaker - Alarm contact |
| | | | | 2-4 2-5 | Source 2 breaker - Alarm contact |

- Note**
- 1: Default 2m cable
 - 2: MX - shunt release 220VAC
XF - Closing coil 220VAC
OF3- Auxiliary contact
AL - Alarm contact
 - 3: The ACB must install with cable interlock
 - 4: out of dotted line is connect to ACB terminal by customer
 - 5: ATS already have under & over voltage protection, do not install undervoltage release into ACB
 - 6: Intelligent controller iTR326H, don't use MODBUS control ACB ON/OFF(MX+XF)



ATS controller-Wiring diagram –ATSEC3

Terminal diagram

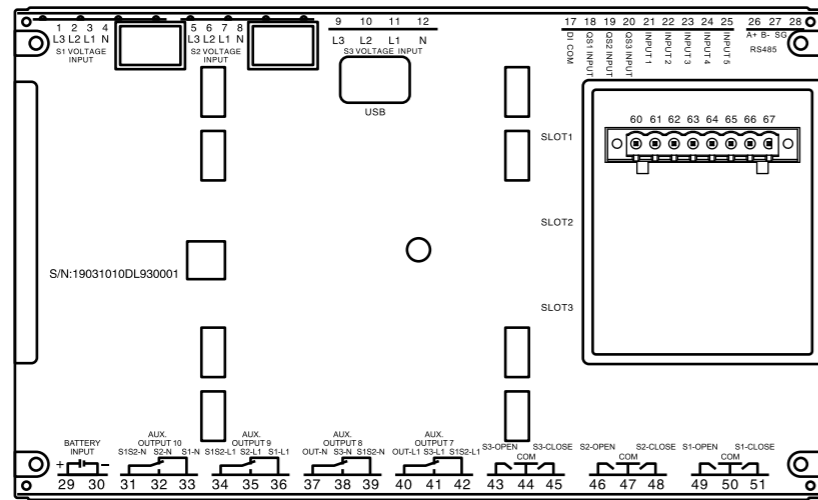

Installation Dimension

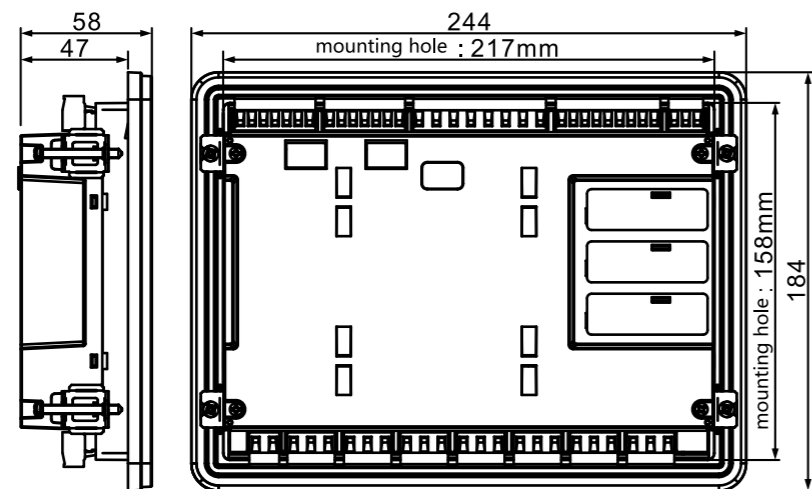

ATS controller-Wiring diagram –ATSEC3

Electrical Schematic Diagram

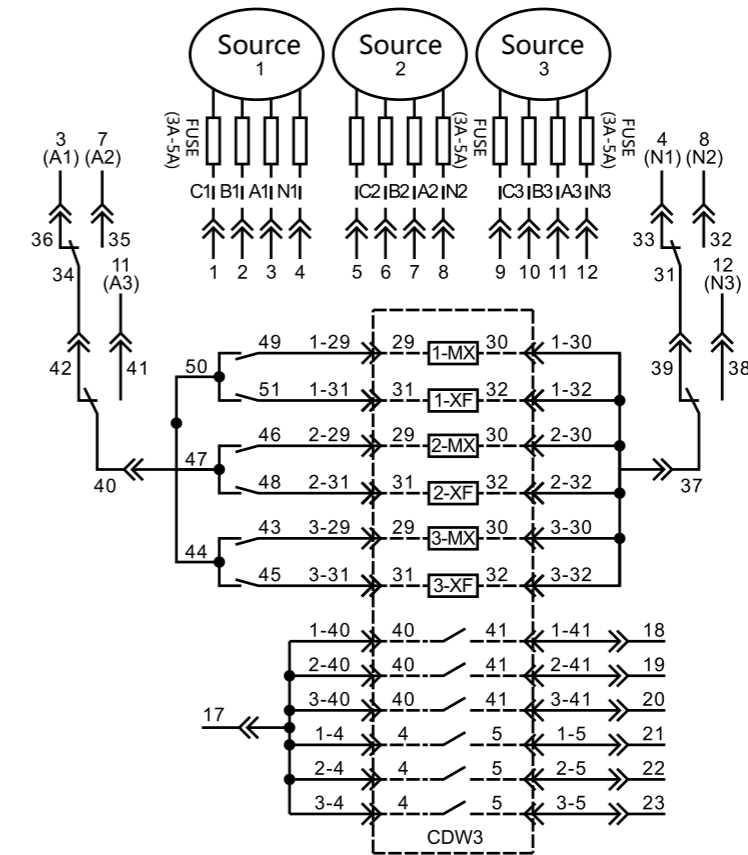

- 1 - MX Source 1 breaker - shunt release
- 1 - XF Source 1 breaker - closing coil
- 2 - MX Source 2 breaker - shunt release
- 2 - XF Source 2 breaker - closing coil
- 3 - MX Source 3 breaker - shunt release
- 3 - XF Source 3 breaker - closing coil
- 1-40 1-41 Source 1 breaker - Auxiliary contact
- 2-40 2-41 Source 2 breaker - Auxiliary contact
- 3-40 3-41 Source 3 breaker - Auxiliary contact
- 1-4 1-5 Source 1 breaker - Alarm contact
- 2-4 2-5 Source 2 breaker - Alarm contact
- 3-4 3-5 Source 3 breaker - Alarm contact

- Note
- 1: Default 4m cable
 - 2: MX - shunt release 220VAC
XF - Closing coil 220VAC
OF3- Auxiliary contact
AL - Alarm contact
 - 3: The ACB must install with cable interlock
 - 4: out of dotted line is connect to ACB terminal by customer
 - 5: ATS already have under & over voltage protection, do not install undervoltage release into ACB
 - 6: Intelligent controller iTR326H, don't use MODBUS control ACB ON/OFF(MX+XF)
 - 7: Not suitable for 1600 frame size



ATS controller-Wiring diagram –ATSECM

Terminal diagram

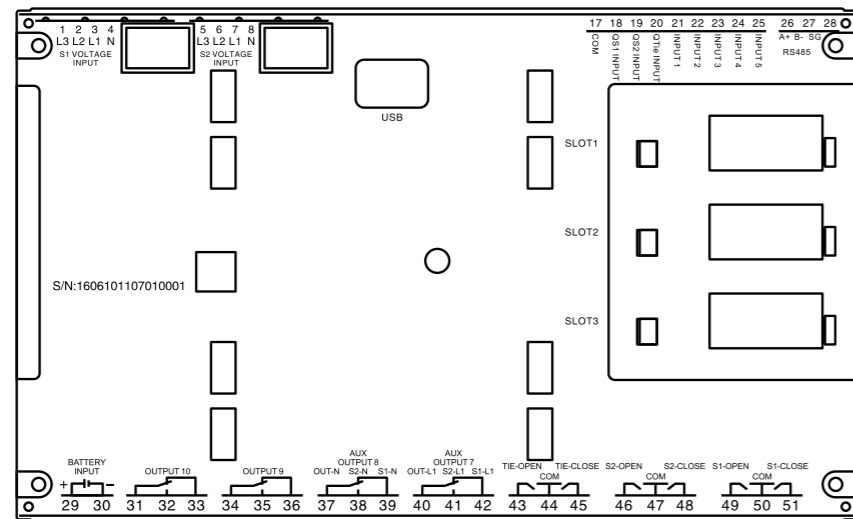

Installation Dimension

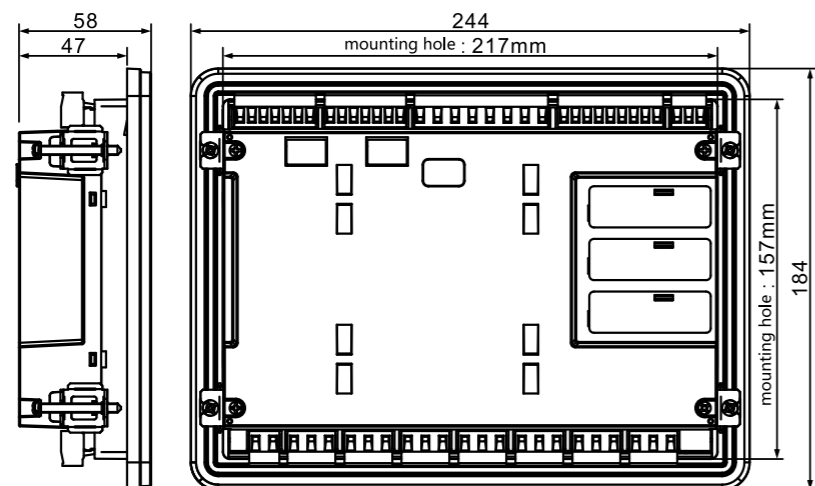

ATS controller-Wiring diagram –ATSECM

Electrical Schematic Diagram

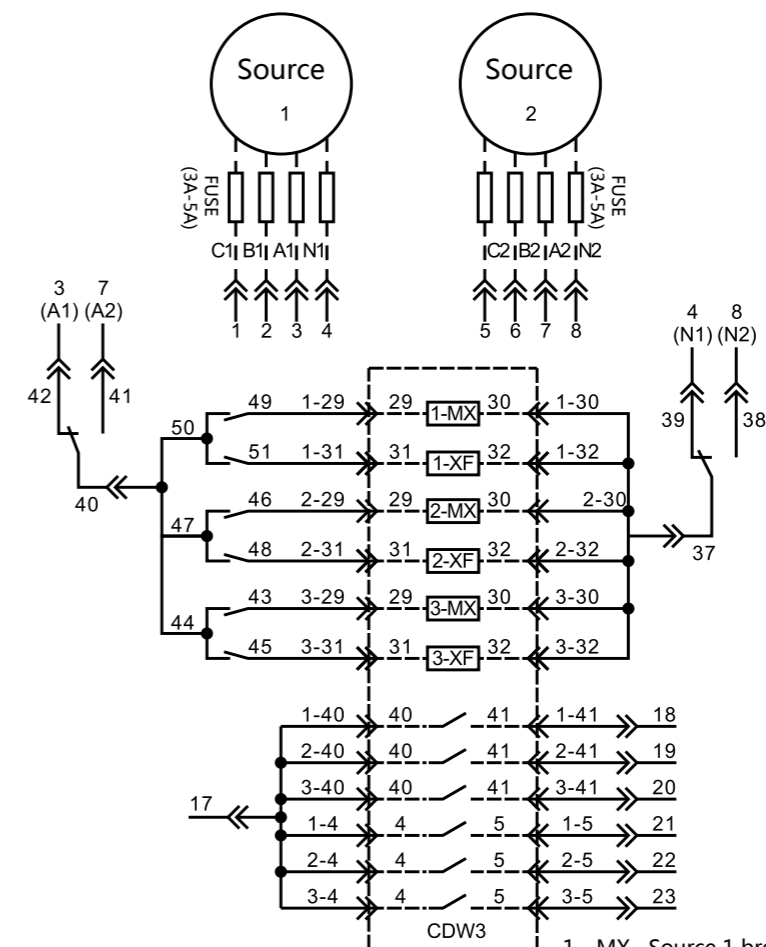

- 1 - MX Source 1 breaker - shunt release
- 1 - XF Source 1 breaker - closing coil
- 2 - MX Source 2 breaker - shunt release
- 2 - XF Source 2 breaker - closing coil
- 3 -MX bus tie breaker - shunt release
- 3 - XF bus tie breaker - closing coil

Note

- 1: Default 4m cable
- 2: MX - shunt release 220VAC
- XF - Closing coil 220VAC
- OF3- Auxiliary contact
- AL - Alarm contact
- 3: The ACB must install with cable interlock
- 4: out of dotted line is connect to ACB terminal by customer
- 5: ATS already have under & over voltage protection, do not install undervoltage release into ACB
- 6: Intelligent controller iTR326H, don't use MODBUS control ACB ON/OFF(MX+XF)
- 7: Not suitable for 1600 frame size



Cable interlock : horizontal

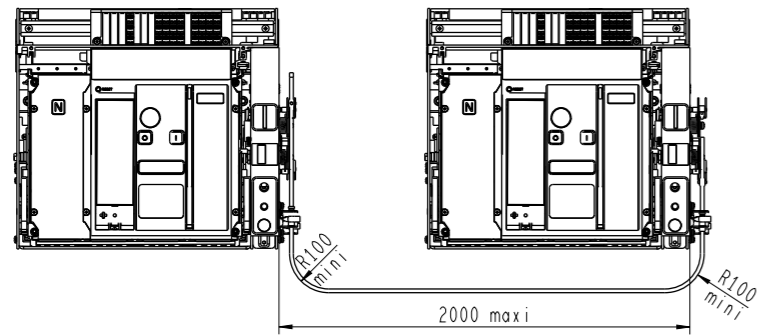

Cable interlock : Vertical

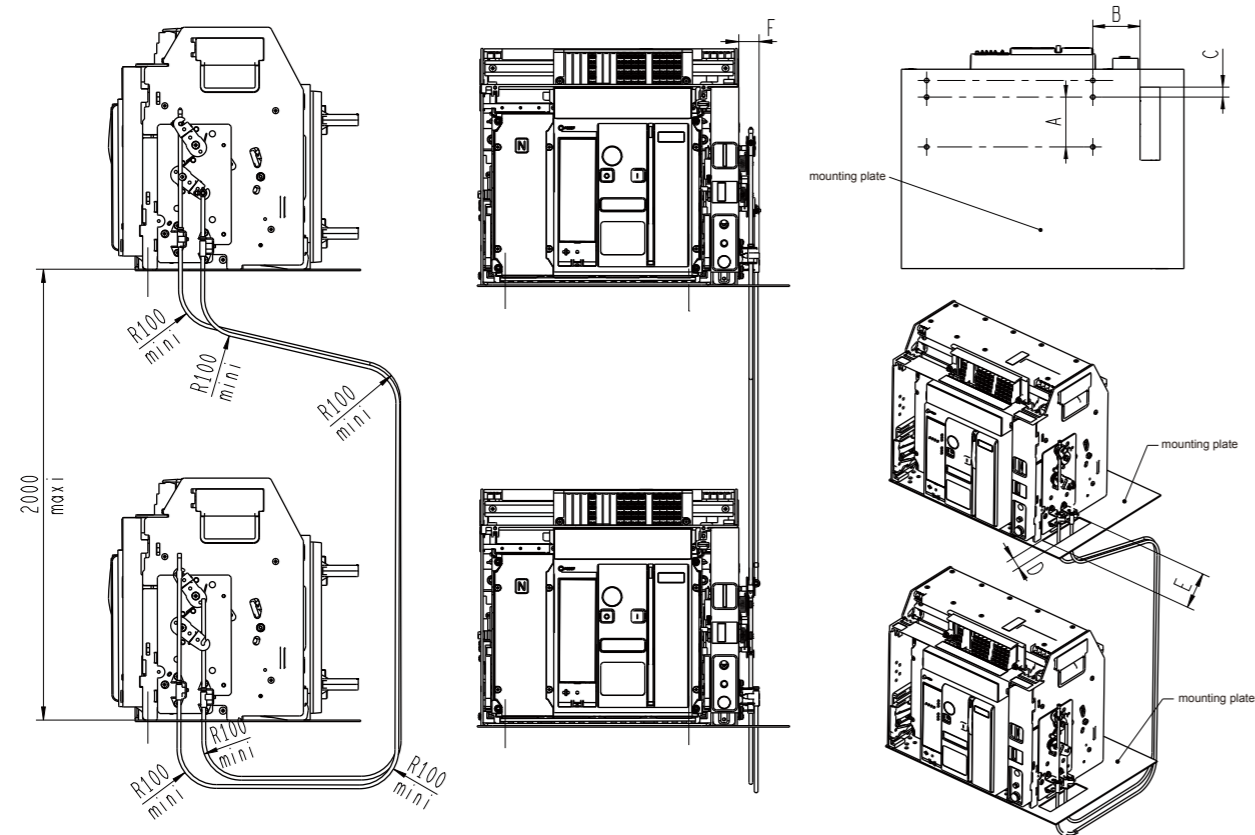

cut off dimension of mounting plate

mm

Frame	A		B		C	D	E	F	
	D/O	Fix	D/O	Fix	D/O & Fix	D/O & Fix	D/O & Fix	D/O	Fix
1600AF	75	75	70	13	25	30	120	28	42
2000AF	175	150	70	13	60	30	180	28	52
3200AF	175	150	70	13	60	30	180	28	52
4000AF	175	124	70	13	60	30	180	40	40
6300AF	175	--	70	--	60	30	180	28	52